



Solis S6 Advanced Power Hybrid Inverter

S6-EH3P(8-15)K-L

Speaker:

Ginlong Technologies Co., Ltd.

7/1/2024





01 Company Profile

02 Product Introduction

03 System Specification

04 Product Features

05 Product basic
Installation and setup

06 Product Parallel
Installation and setup

07 Product Professional
Functions

08 Solis Products

09 Reliability

CONTENTS



01

Company Profile

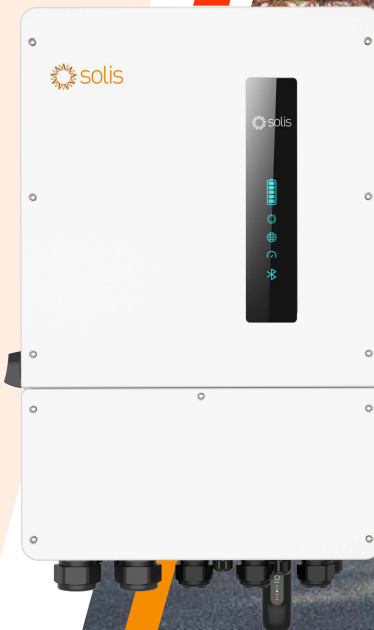

Solis - Global Manufacturer of Solar & Energy Storage Solutions

Developing technology
to power the world with clean energy



NO.

Ginlong(Solis) ranked the NO.3 PV inverter
supplier globally in shipment

Company Profile



Global Employees



Total Assets



R&D Team

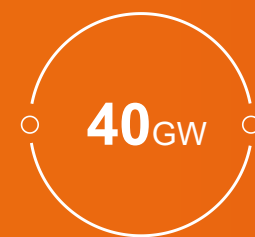

Capacity



Global Installation

Marketing Share

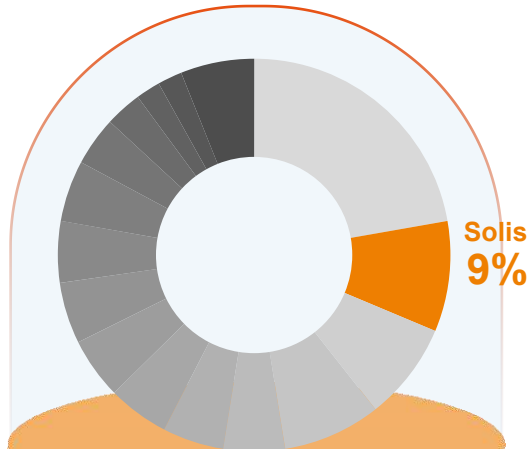

No. 2 Global Single-Phase Inverter market shares, full year 2019(MWac)

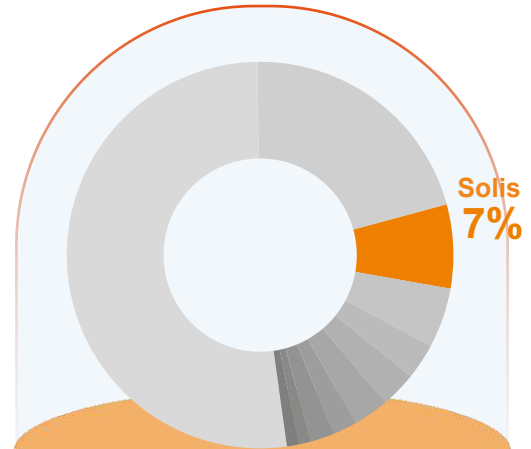

No. 3 Global Three-Phase Inverter market shares, full year 2020(MWac)

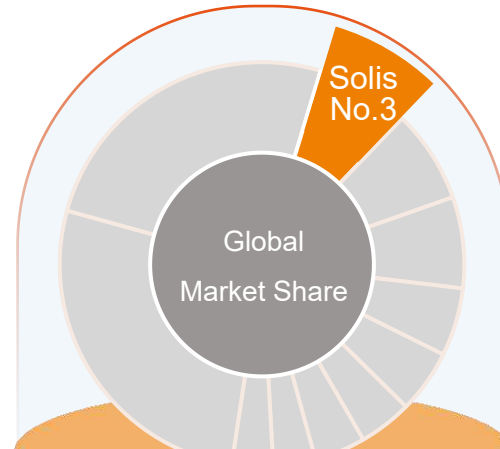

NO.3 Global market shares in 2021

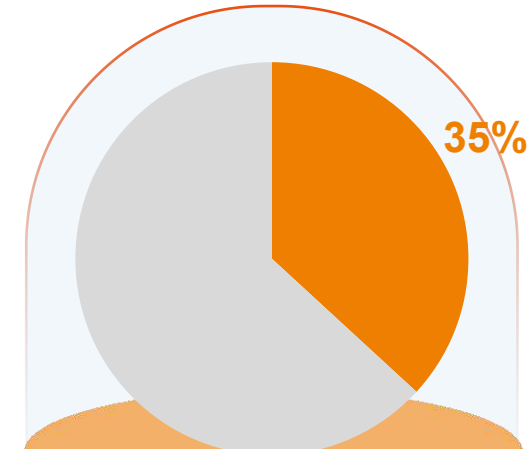

NO.1 Chinese Residential market shares in 2021

Source : Wood Mackenzie / IHS /Online Data

Sales increased up to **882.98** million USD dollars in 2022 ,
Growth v's the same period last year of **77.8%**.

Revenue



Sales are booming

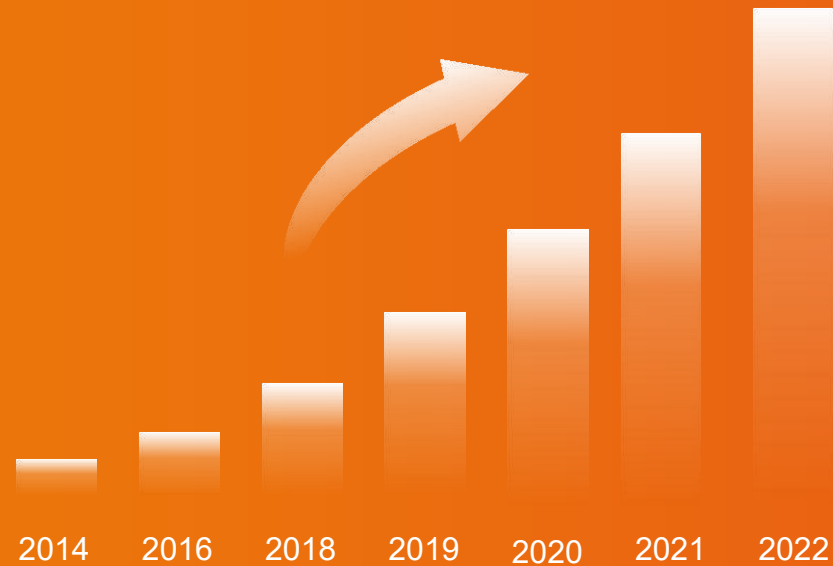

Shipments

— MW



Leader in string inverter technology reaching 60GW global shipment milestone



○ Manufacturing Base Introduction

Equipped with fully automated and real-time collection production lines for logistics, production and testing. This includes SMT lines, DIP special-shaped plug-in lines, triple anti-coating lines, automatic assembly lines, aging inspection and packaging integrated production lines. The implementation of intelligent material transport system, AGV, automatic manipulator palletizing system, three-dimensional warehouse and other logistics engineering construction, enables automatic material in and out of storage, production line pulling material distribution and visual management.

02

Product Introduction

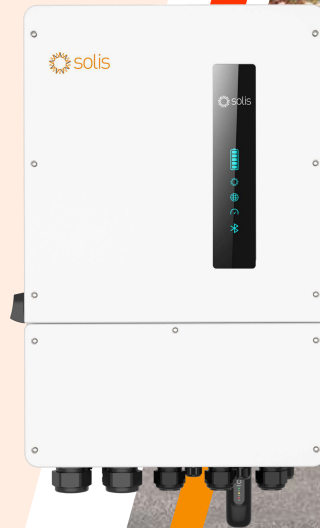

Solis S6 Advanced Power Hybrid Inverter

S6-EH3P(8-15)K-L

S6-EH3P(8-15)K-L-LD

8K/10K/12K/15K





Screen version

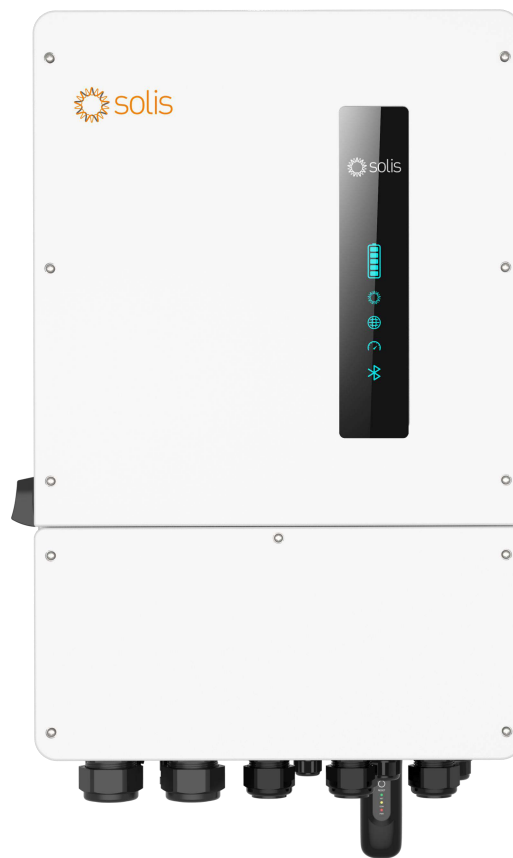

No-screen version



Bottom & Communication Interface



S6-EH3P(8-15)K-L



◆ For details of the interface definition, see the product manual.

Junction Box

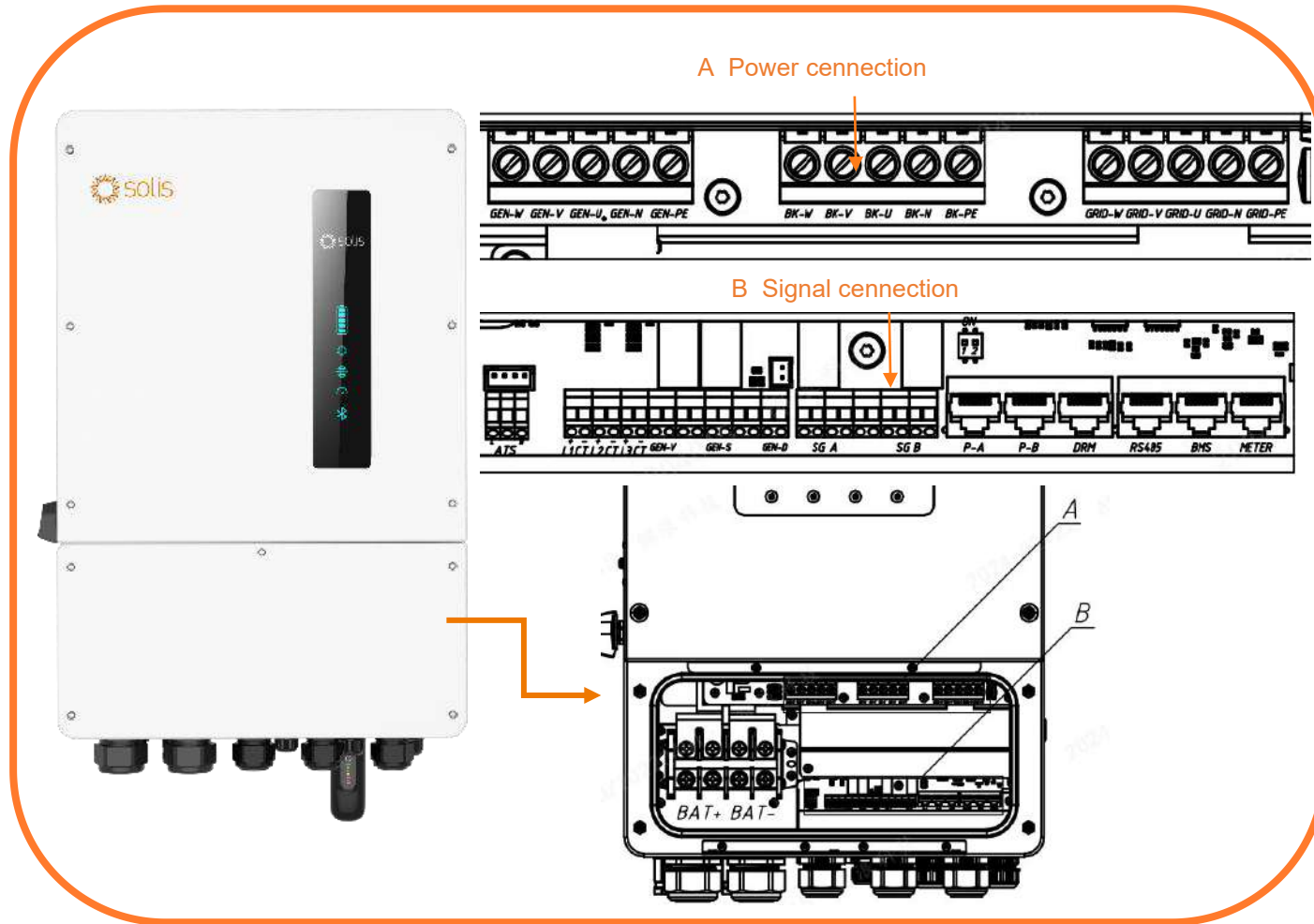

◆ Communication Specification

External communication Interface	Communication Object	Communication protocol
Battery communication Interface (BMS)	BMS	CAN
Meter communication interface	Smart Meter	RS485
Monitor Interface (COM)	Solis Monitor Devices	RS485
Grid Dispatch Interface (DRM)	Grid Dispatch System	Modbus RTU
RS485 Interface (RS485)	Third-party external devices	RS485
Parallel Interface (Parallel A)	Other inverters	CAN
Parallel Interface (Parallel B)	Other inverters	CAN

- CAN communication is recommended for battery communication. If RS485 is needed, please contact the product manager ;

◆ For details of the connections , see the product manual.

Inverter Indicator Diagram (No-screen version)

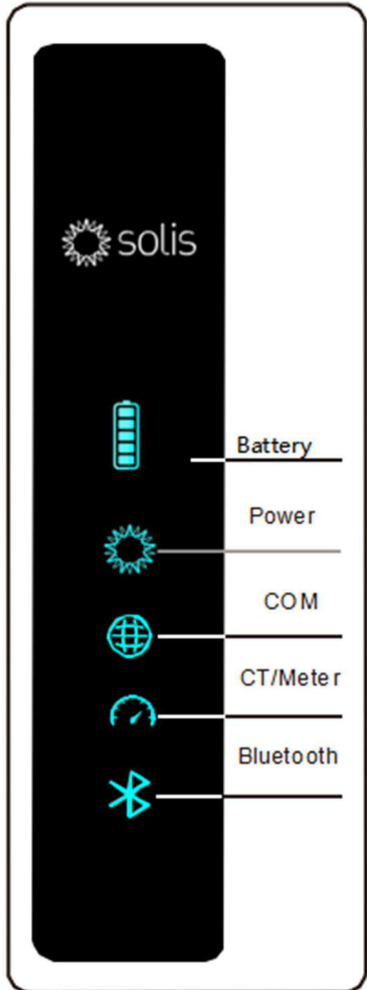

Indicator	Status	Description	
Battery	OFF	No battery/not running	
	ON	Breathing light flashes	charging
		Breathing light flashes	discharging
	blue solid on	No charging, no discharging	
yellow solid on	BMS warning		
Power	OFF	not running	
	ON	flashing 3S per cycle	waiting
		blue solid on	runing
	yellow solid on	warning	
red solid on	Alarm		
COM	OFF	External collector failed to connect to the internet	
	blue solid on	External collector successfully connected to the internet	
CT/Meter	OFF	CT/Meter failed to communicate with inverter	
	blue solid on	Grid side CT/Meter Successfully communicated with inverter	
Bluetooth	OFF	not running	
	blue solid on	Connected and running normally	

Inverter Indicator Diagram (screen version)



There are three LED indicators on the RHI inverter (Red, Green, and Orange) which indicate the working status of the inverter.



Light	Status	Description
● POWER	ON	The inverter can detect DC power.
	OFF	No DC power.
● OPERATION	ON	The inverter is fully operational.
	OFF	The inverter has stopped operating.
	FLASHING	The inverter is initializing.
● ALARM	ON	Fault condition is detected.
	OFF	No fault condition detected.
	FLASHING	Either the grid or solar cannot be detected.

Product Features of S6 Advanced Power Hybrid Inverter

- Up to 20A input current, perfectly match high current PV module;
- High efficiency charge/discharge up to 290A;
- Support both lithium batteries and lead-acid batteries, compatible with various battery brands;
- 10 second 200% overload capability on backup port, switching time < 10 ms;
- Support Max 6 pcs in parallel, up to 90KW;
- Support Unbalanced and Half-Wave Loads on both the Grid and Backup Port;
- Built-in Port to connect Diesel Generator and Third-party inverter, applicable to off-grid scenario and the retrofit of a existing PV plant;
- IP66: high environment adaptability;
- Battery reserve function to meet the backup demand when power outage;
- Support 2backup function and smart load function;



Work Modes



	Working mode	Working logic	Usage
<p>at night</p>	Self of use	<p>Load priority: load>battery>grid</p> <p>Power supply priority: PV>battery>grid>DG</p> <p>Support TOU setting in this mode.</p> <p>Support Battery reserve in this mode.</p>	This mode applies the area that has low feed-in tariff and high energy price.
	Feed in priority	<p>Load priority : load>grid>battery</p> <p>Power supply priority: PV>battery>grid>DG</p> <p>Support TOU setting in this mode.</p> <p>Support Battery reserve in this mode.</p>	This mode applies the area that has high feed-in tariff.
<p>6kW 4kW 10kW 0kW</p>	Off-grid	<p>Load priority : load>battery</p> <p>Power supply priority: PV>battery>DG</p> <p>When a power outage is detected, the system will automatically enter the off-grid mode, supplying only the backup load.</p>	This mode applies the area not covered by the grid or the system is not connected to the grid.
<p>3kW 2kW 10kW 5kW(Pmax)</p> <p>I II III Power consumption priority</p>	Peak-shaving	<p>Load priority: load>battery>grid</p> <p>Power supply priority: PV>grid>battery>DG</p> <p>Support TOU setting in this mode.</p> <p>In this mode , on the premise that the power supplied by the grid does not exceed the set value(P_max), the system will be trying to charge the battery to Peak SOC.</p> <p>If $(P_{\text{discharge}}+P_{\text{max}}+PV < P_{\text{load}})$, it will exceed the set value(P_max) to support the load.</p>	This mode applies the area where the electricity tariff is calculated according to the maximum power per unit time.

Product Datasheet



Models	8K	10K	12K	15K
Input DC (PV side)				
Recommended max PV array size	16 kW	20 kW	24 kW	30 kW
Max Usable PV Input Power	12.8 kW	16 kW	19.2 kW	24 kW
Max. input voltage	1000 V			
Rated voltage	550 V			
Start-up voltage	160 V			
MPPT voltage range	200-850 V			
Max. input current	20 A / 40 A		40 A / 40 A	
Max. short circuit current	30 A / 50 A		50 A / 50 A	
MPPT number/Max. input strings number	2/3		2/4	
Battery				
Battery type	Li-ion / Lead-acid			
Battery voltage range	40 - 60 V			
Max. charge / discharge current	290 A			
Battery switch	Optional			
Communication	CAN/RS485			
Output AC (Grid side)				
Rated output power	8 kW	10 kW	12 kW	15 kW
Max. apparent output power	8 kVA	10 kVA	12 kVA	15 kVA
Operation phase	3/N/PE			
Rated grid voltage	380 V / 400 V			
Rated grid frequency	50 Hz / 60 Hz			
Rated grid output current	12.2 A / 11.5 A	15.2 A / 14.4 A	18.2 A / 17.3 A	22.8 A / 21.7 A
Max. output current	12.2 A / 11.5 A	15.2 A / 14.4 A	18.2 A / 17.3 A	22.8 A / 21.7 A
Power factor	>0.99 (0.8 leading - 0.8 lagging)			
THDi	<3%			
Input AC (Grid side)				
Input voltage range	323-460 V			
Max. input current	60 A			
Frequency range	45-55 Hz / 55-65 Hz			
Input Generator				
Max. input power	8 kW	10 kW	12 kW	15 kW
Max. input current	12.2 A	15.2 A	18.2 A	22.8 A
Rated input voltage	3/N/PE, 380 V / 400 V			
Rated input frequency	50 Hz / 60 Hz			

Product Datasheet



Output AC (Back-up)				
	8 kW	10 kW	12 kW	15 kW
Rated output power	8 kW	10 kW	12 kW	15 kW
Max. apparent output power	2 times of rated power, 10 s			
Back-up switch time	<10 ms			
Rated output voltage	3/N/PE, 380 V / 400 V			
Rated frequency	50 Hz / 60 Hz			
Rated output current	12.2 A / 11.5 A	15.2 A / 14.4 A	18.2 A / 17.3 A	22.8 A / 21.7 A
Max. Continuous output current	12.2 A	15.2 A	18.2 A	22.8 A
Max. Continuous AC Passthrough current	60 A			
THDv (@linear load)	<2%			
Efficiency				
Max. efficiency	97.6%			
EU efficiency	97.0%			
Protection				
Anti-islanding protection	Yes			
Output over current protection	Yes			
Short circuit protection	Yes			
DC reverse-polarity protection	Yes			
Surge protection	AC Type II (Type I+ II Optional)			
General Data				
Dimensions (W*H*D)	422*702*281 mm			
Weight	33.6 kg			
Topology	Non-isolated			
Operating ambient temperature range	-40 ~ +60°C			
Ingress protection	IP66			
Cooling concept	Intelligent redundant fan-cooling			
Max. operation altitude	4000 m			
Grid connection standard	NRS 097-2-1, IEC 62116, IEC 61727, IEC 60068, IEC 61683, EN 50530, SriLanka, EN 50438L, Vietnam			
Safety/EMC standard	IEC/EN 62109-1/-2, IEC/EN 61000-6-1/-3			
Features				
DC connection	MC4 Quick connection plug (PV) & Screw terminal (Battery)			
AC connection	Screw terminal			
Display	LED + Bluetooth + APP			
Communication	CAN, RS485, Ethernet, Optional: Wi-Fi, Cellular, LAN			

03

System Specification



System with Smart load

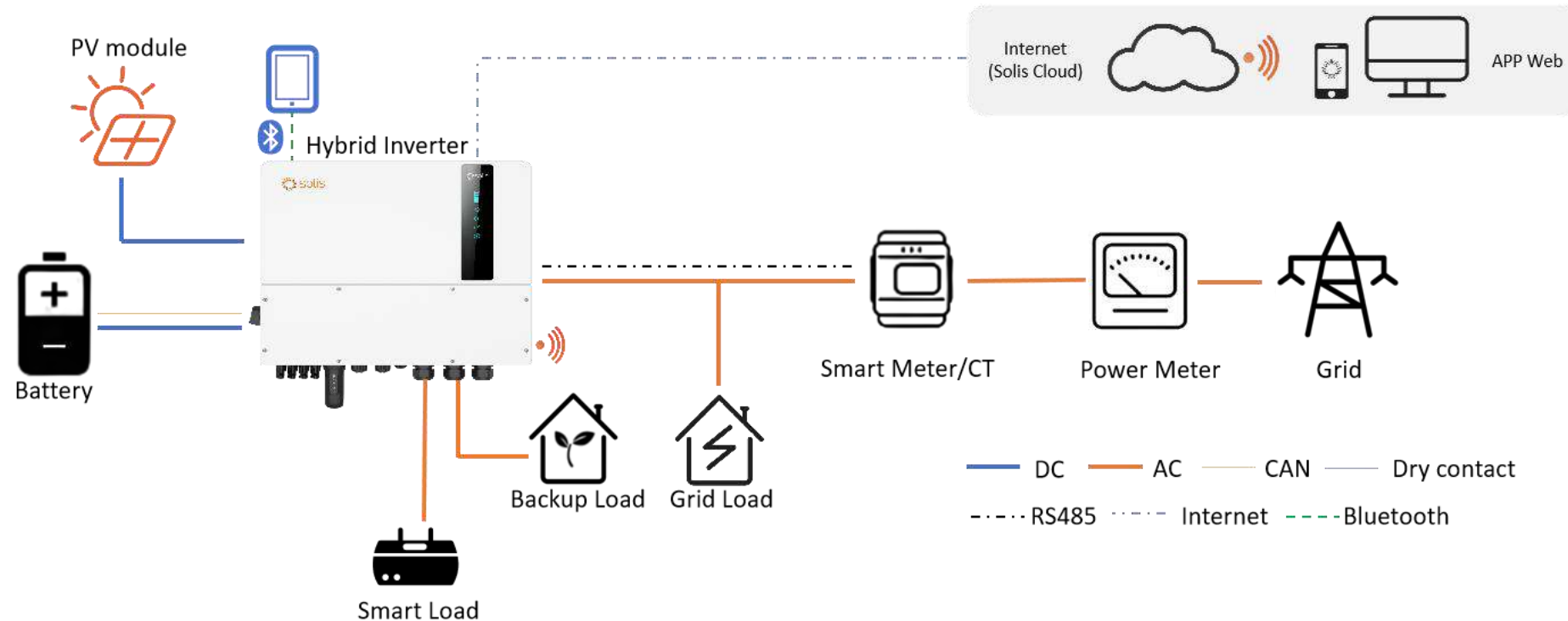

- **Smart load work logic 1:** When the power fed into grid is greater than a certain value, the system will automatically open the gen port load power supply to consume excess PV energy.
- **Smart load work logic 2:** During power outage, user can set priorities to power some non-critical loads used temporarily. When the battery energy drops to a certain level, the system will automatically cut off the power supply of these non-critical loads to ensure the power supply of critical loads. when the grid is available, the load on gen port powered by the grid.

Parallel system

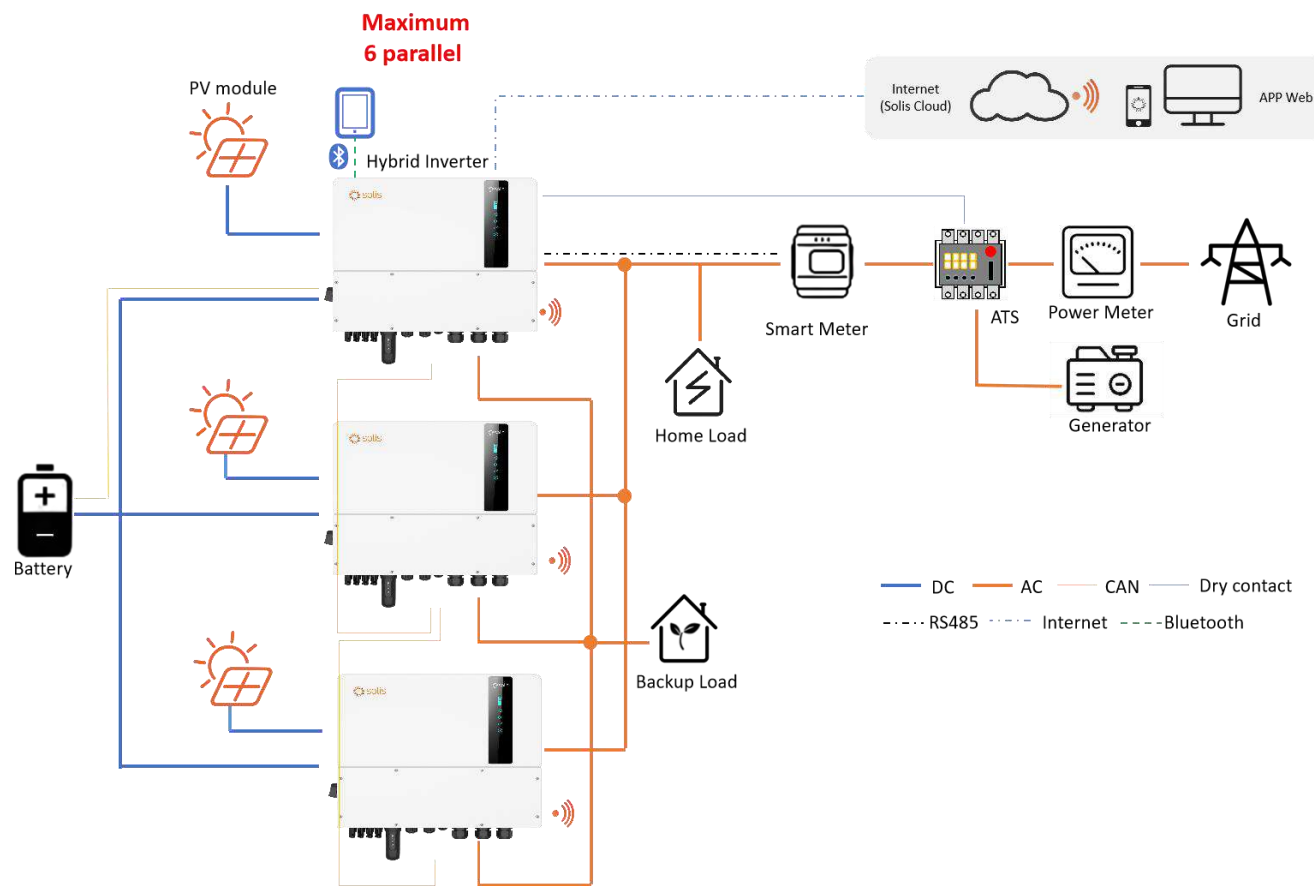

- Support maximum 6 in parallel, up to 90KW;
- Parallel connection of different models is not supported. (Like 10K and 12K can't be connected in parallel).
- In parallel-system scenarios, connecting DG via ATS is recommended;

System with Generator



Generator on Generator port

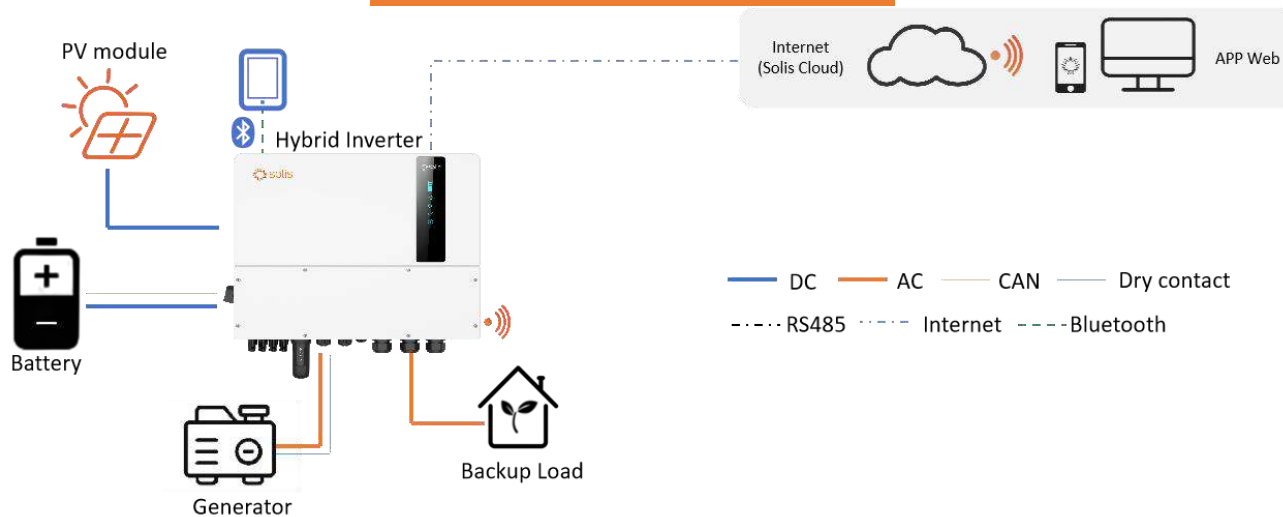

Generator on Grid side

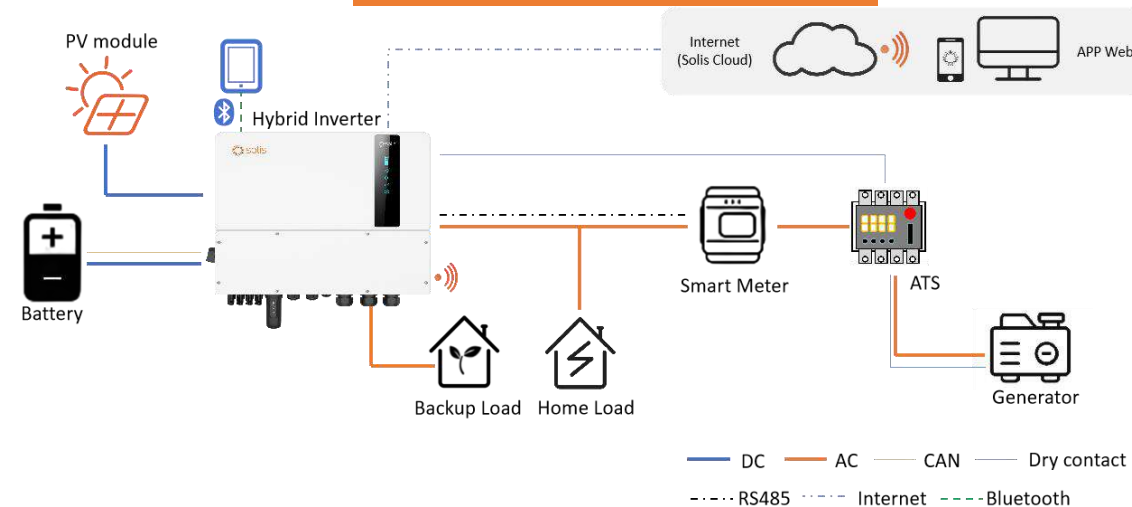

NOTE:

- In single system, Diesel Generator can be connected via GEN port or ATS on Grid side. If through GEN port, it will only supply power to the Backup load ; if it is necessary to supply power to the grid side load, it is recommended that the generator be connected through ATS on grid side ;
- In parallel-system scenarios, connecting DG via ATS is recommended;
- When the generator is connected to the system, it is necessary to correctly select the location of the generator on the APP to avoid system failure or generator damage ;

Generator control logic



Generally, the access of Diesel Generator is in the off-grid scenario, or in the area that has frequent power outages.

Work logic is as follows:

- I. when the grid is power outage, the battery is discharged to GEN_Start_SOC, the generator starts to power the load and charge the battery to GEN_Exit_SOC, then stop the generator.
- II. If the load power > the generator rated power in (i), the battery will be discharged to power the load to until Overdischarge_SOC, then generator may shutdown due to overload and the load power off.
- III. If the generator fail to start in (i), the battery will be discharge to Overdischarge_SOC, then the load power off.
- IV. If the system goes into the end of (iii), the battery will not discharge before charged to Overdischarge_SOC + Overdischarge_Hysteresis_SOC (set by user).

Control logic is as follows:

The logic of DG control:

- To start the generator, relay pull-in, dry contact short circuit.
- To stop the generator, relay release, dry contact open circuit.

The logic of ATS control:

- Output 230V AC voltage when inverter is connected to the grid .
- when output is 0V, the ATS switch to connecting generator.

System with Grid-tied Inverter



Grid-tied Inverter on Backup port

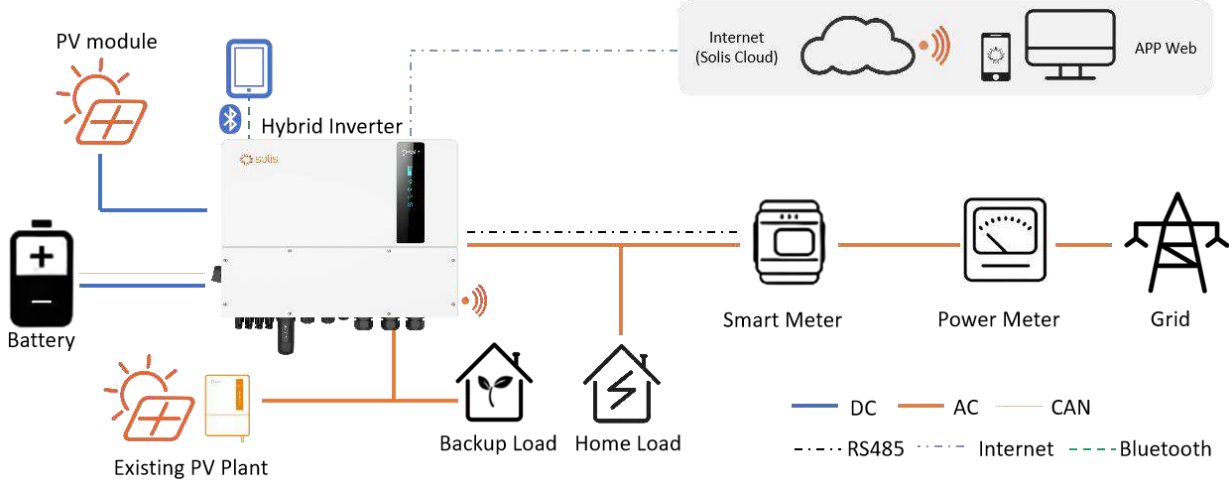

Grid-tied Inverter on Gen port

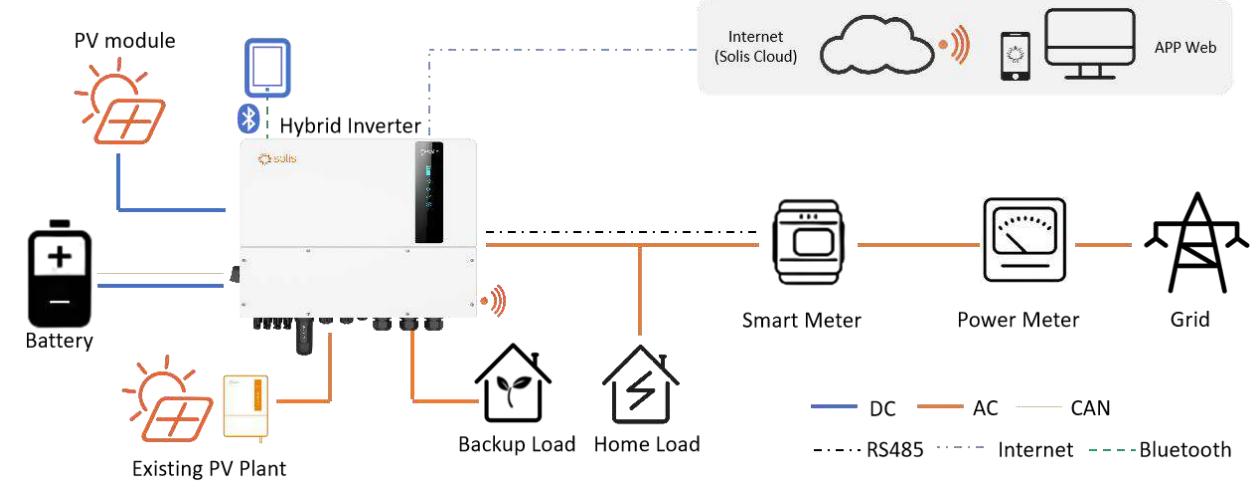

NOTE:

Grid-tied inverter can be connected via AC-Gen port and AC-Backup port.

- With existing PV Plant connected to the system, it is recommended that : Grid-tied inverter power < rated AC power of S6 inverter ;
- In on-grid scenario, when the third-party grid-tied inverter is connected, the system cannot control the output power of the third-party grid-tied inverter, so Feed-in limitation cannot be realized ;
- When connected in off-grid scenario, the third-party grid-tied inverter needs to set the correct grid code, and has the function of over-frequency load shedding & under-frequency load rising, so that the system can adjust the frequency to control the output power of the grid-tied inverter.
- The solis grid-tied inverter can be connected with Hybrid inverter in parallel . In order to realize Feed-in limitation, it is necessary to add EPM or S3-Logger devices.
- When the system is connected to the generator, it cannot be connected to the grid-tied inverter, because of a risk of damaging the generator ;

Grid-tied Inverter control logic



◆ Grid-tied inverter

The working logic is as follows:

- On-grid operation logic :

PV-hybrid + PV-grid-tied power the load and then charge the battery, the excess power will be fed into the grid. The system does not restrict the output power of AC coupled Grid-tied Inverter.

- Off-grid operation logic :

PV-hybrid + PV-grid-tied power the load and then charge the battery, until the battery reaches AC Coupling-OFF-SOC, the system will restrict the output power of AC coupled Grid-tied Inverter to zero.

Key Functions



Functions	Working logic	Usage
TOU function	Support 6 customisable charge/discharge time settings, while the battery will charge/discharge at a set current.	This function applies the area with Peak-valley Price, set the system to charge the battery in valley price and discharge in peak price to improve benefits.
Battery reserve function	Load Priority: battery>load>grid Power supply priority: PV>grid	This function applies the area that has frequent power outages, to ensure that battery have enough power to supply when grid is off.
Feed in power limit function	Feed in power will be limited according to the set value.	This mode applies the area that has export control.
2 Backup function	During power outage, user can set priorities to power some non-critical loads used temporarily. When the battery energy drops to a certain level, the system will automatically cut off the power supply of these non-critical loads to ensure the power supply of critical loads.	/
Smart load function	When the power fed into grid is greater than a certain value, the system will automatically open the gen port load power supply to consume excess PV energy.	Improve self-use proportion
ECO function	To protect the battery, If PV power is lower than 100W and SOC below overdischarge SOC, The inverter will take power from the grid instead of battery, to maintain standby state, indicator and communication.	/
Battery Wake up function	Battery wake-up can be supported in case of only PV or only Grid. This function supports manual and automatic operation, the battery can be awakened from the dormant state and charged above the overdischarge SOC. Wake up voltage&time can be set: Voltage: default 120V, range :120-600V; Time : default 180s, range :20s-300s; The wake up current depends on the battery, up to 6A.	/
Battery Healing Function	When the lithium battery maintains low power for a long time, the battery SOC measurement is not accurate. It is necessary to charge the battery to 100 % from low power level to ensure the healthy and stable operation of the battery. Working logic: PV+grid charge the battery from Forcecharge SOC to overdischarge SOC, then grid stops charging, PV gives priority to charging the battery to Battery Healing SOC. And the battery does not discharge before reaching the set Battery Healing SOC.	/
Battery Peak shaving function	In this function, the force charge power will be dynamically adjusted and not exceed the set value minus the load power when force charging.	/

Capacity configuration



- The required output voltage range of third-party battery is 40V ~ 60V, support both lithium and lead-acid batteries;
- The AC-Backup port can be connected in parallel, and the single-phase output power is 1 / 2 of the total AC power.
- With existing PV Plant connected to the system, it is recommended that : Grid-tied inverter power < rated AC power of S6 inverter ;

Scenarios	S6-EH3P10K-L	S6-EH3P12K-L	S6-EH3P15K-L	Backup Parallel output capability (For 12K)	Backup signal-phase output (For 12K)	Battery Capacity Recommendation (For 12K, Backup 2h, 0.5C)
	AC capacity	AC capacity	AC capacity			
1 single	10K	12K	15K	/	6K	24KWh
2 in parallel	20K	24K	30K	24K	12K	48KWh
3 in parallel	30K	36K	45K	36K	18K	72KWh
4 in parallel	40K	48K	60K	48K	24K	96KWh
5 in parallel	50K	60K	75K	60K	30K	120KWh
6 in parallel	60K	72K	90K	72K	36K	144KWh

System Adaptation



- The S6 three-phase high-voltage inverter is applicable to both lithium and lead-acid batteries, (see the compatible list for specific models).

Adaptation Object	S6-EH3P8K-L	S6-EH3P10K-L	S6-EH3P12K-L	S6-EH3P15K-L
W4G dongle	√	√	√	√
GPRS/WIFI dongle	√	√	√	√
WIFI dongle	√	√	√	√
WL dongle	√	√	√	√
Lithium Battery	√	√	√	√
Lead-acid Battery	√	√	√	√
CT	√	√	√	√
Smart Meter	√	√	√	√

04

Product Features



Advantages of Connecting Through Solis App



1. Bluetooth connection to mobile phone, make the setting and operation easier.

- 01** With large screen display of the phone, More rich, easier to operate, more humanistic characteristics.

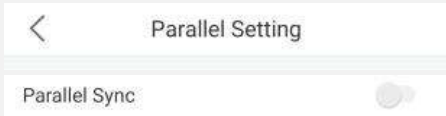

- 02** In the establishment of parallel system, with synchronization Settings, fast and efficient

- 03** Log in to the APP, it can distinguish the identity of the login account to avoid the normal operation the inverter caused by misoperation.

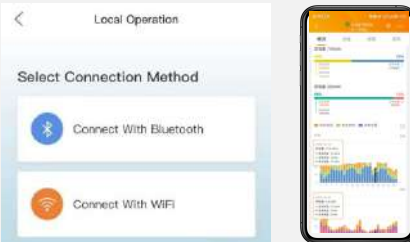

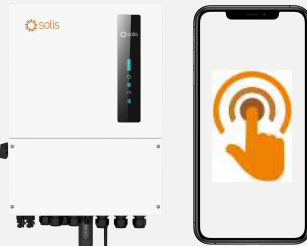
- 04** Support Bluetooth connection, realize APP view system operation.



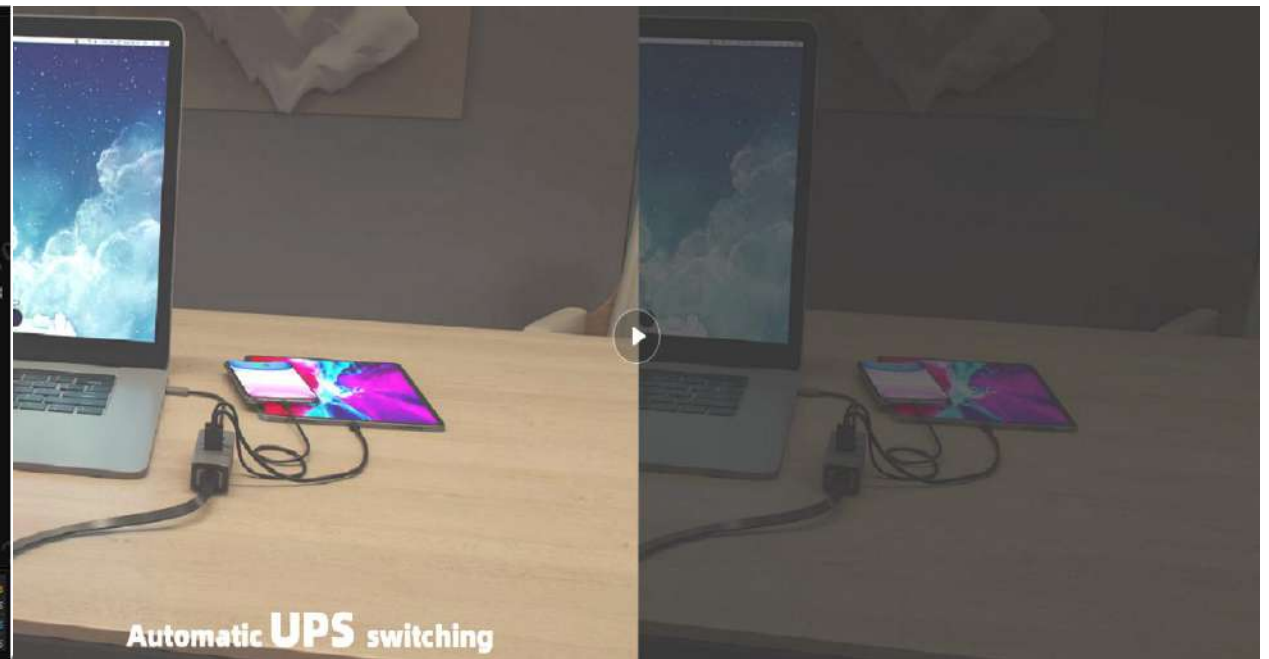

- 05** APP has step storage function, to achieve one key setting.

- 06** The inverter can be upgraded from the near end for rapid stability.



2. Automatic UPS switching, switching <math>< 10\text{ms}</math>



-  CH1: Back up voltage waveform
-  CH2: Back up current waveform
-  CH4: Grid current waveform

Product Advantage - Strong Power Supply Stability



3.10 second 200% surge power backup overload capability

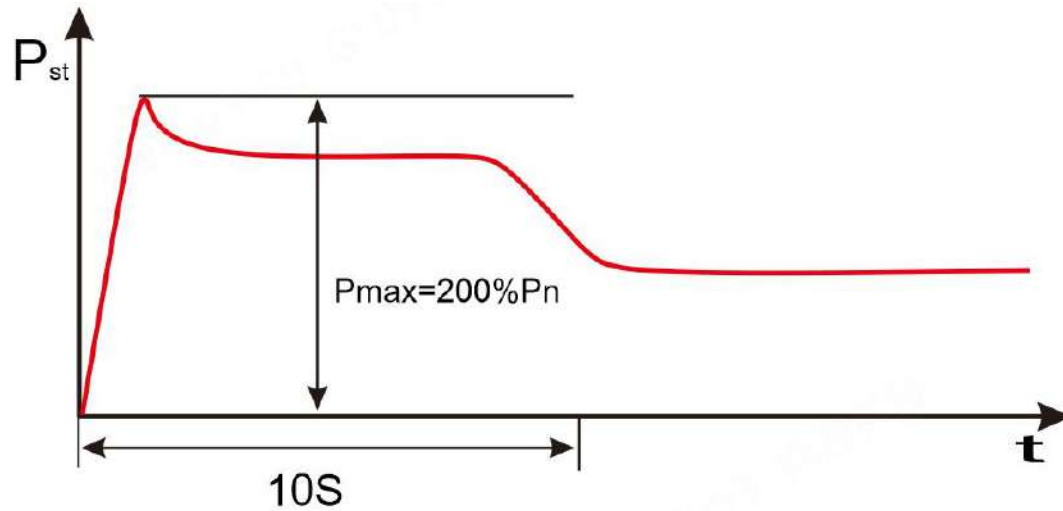

This function has stronger energy supply stability when the inductive load is switched. It will not cause the sudden start of large load, resulting in the sudden drop of system supply voltage

Supports peak shaving control in both grid and generator condition.

Application scenarios of Peak shaving:

1. when the electric load power exceeds a certain value (for example 10kW), the electricity tariff will increase several times
2. The area where the electricity tariff is calculated according to the maximum power taken per unit time

Peakshaving functional logic:

Peakshaving function allows user to set the maximum power of shaving power from the grid, which ensures that it is less than this power while satisfying load operation. It can greatly reduce users' electricity bills

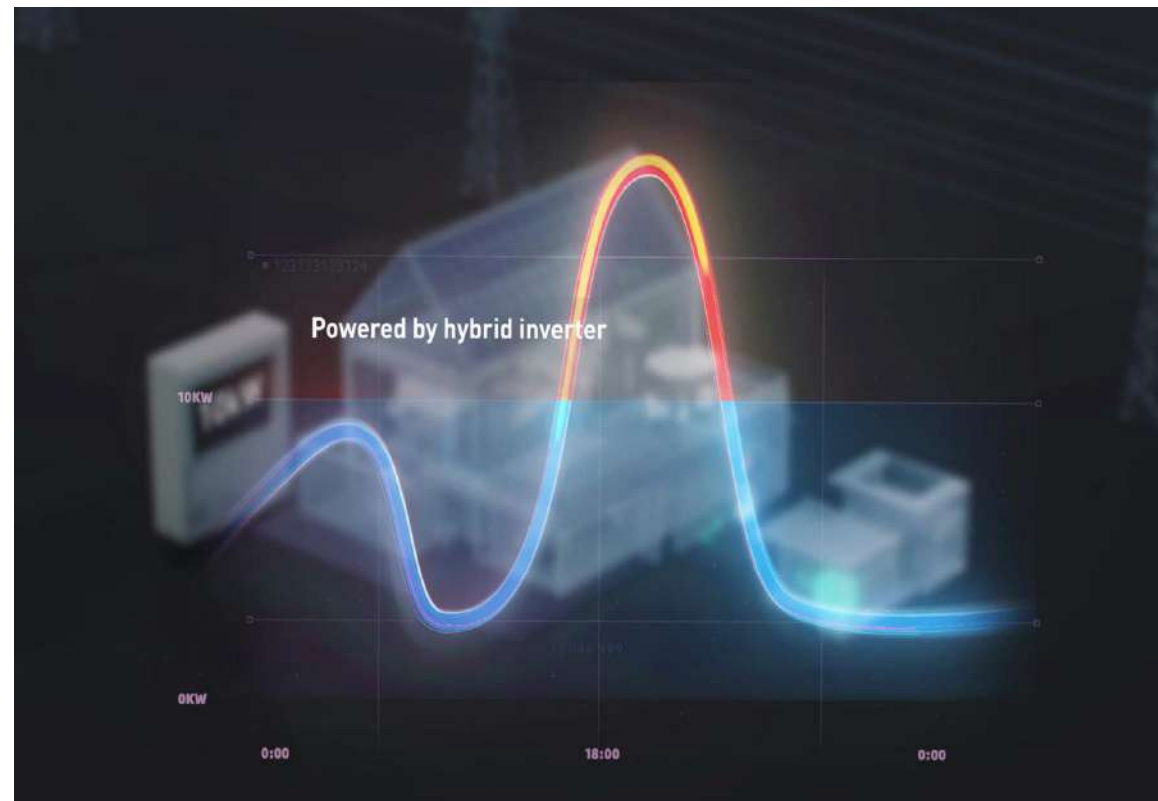

Product Advantage - Supports Peak Shaving in Different Scenarios



Supports peak shaving control in both grid and generator condition.

Peak shaving (Generator)

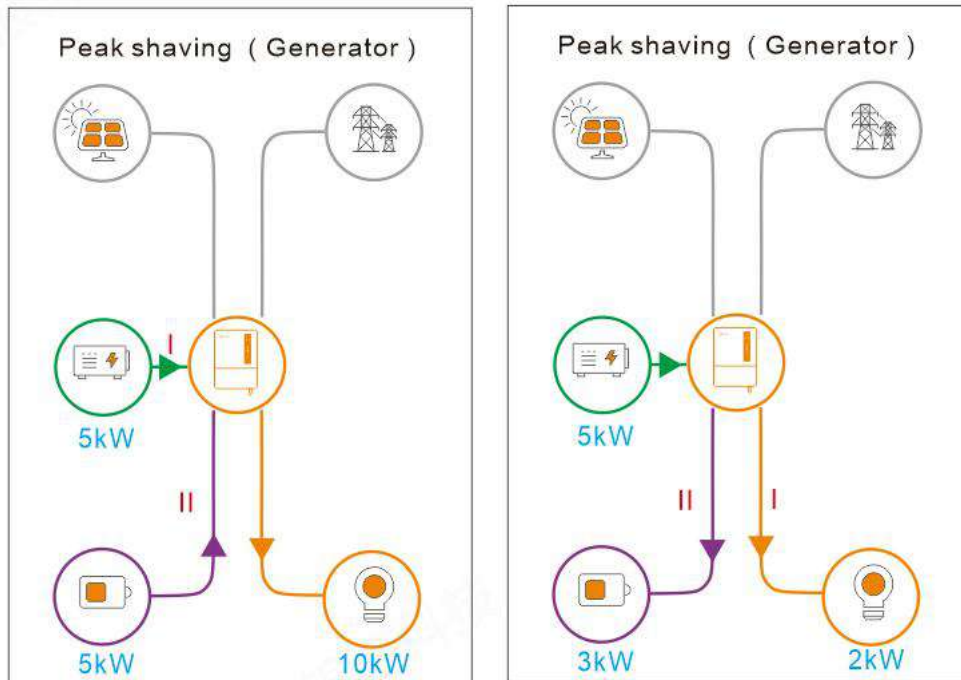

Loads > generator,
Generator + battery supplies
power to the loads

Loads < generator,
The generator charges the
battery

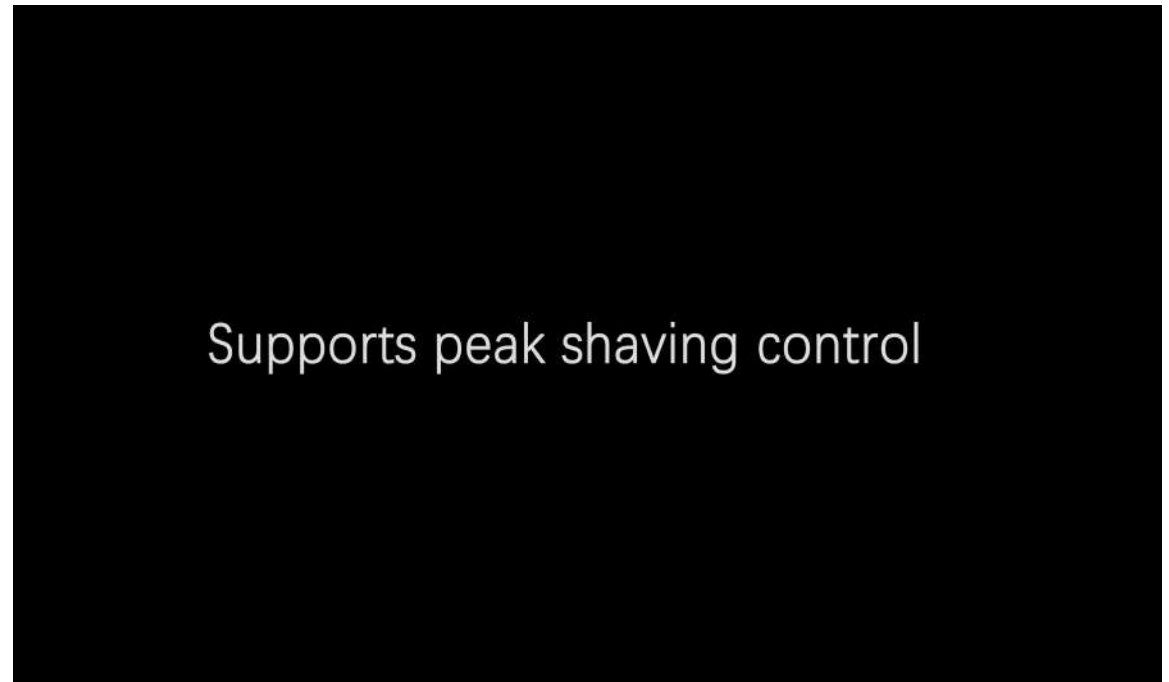

04

Application Scenario



Residential Single Scenario with Smart Load (8~15KW)

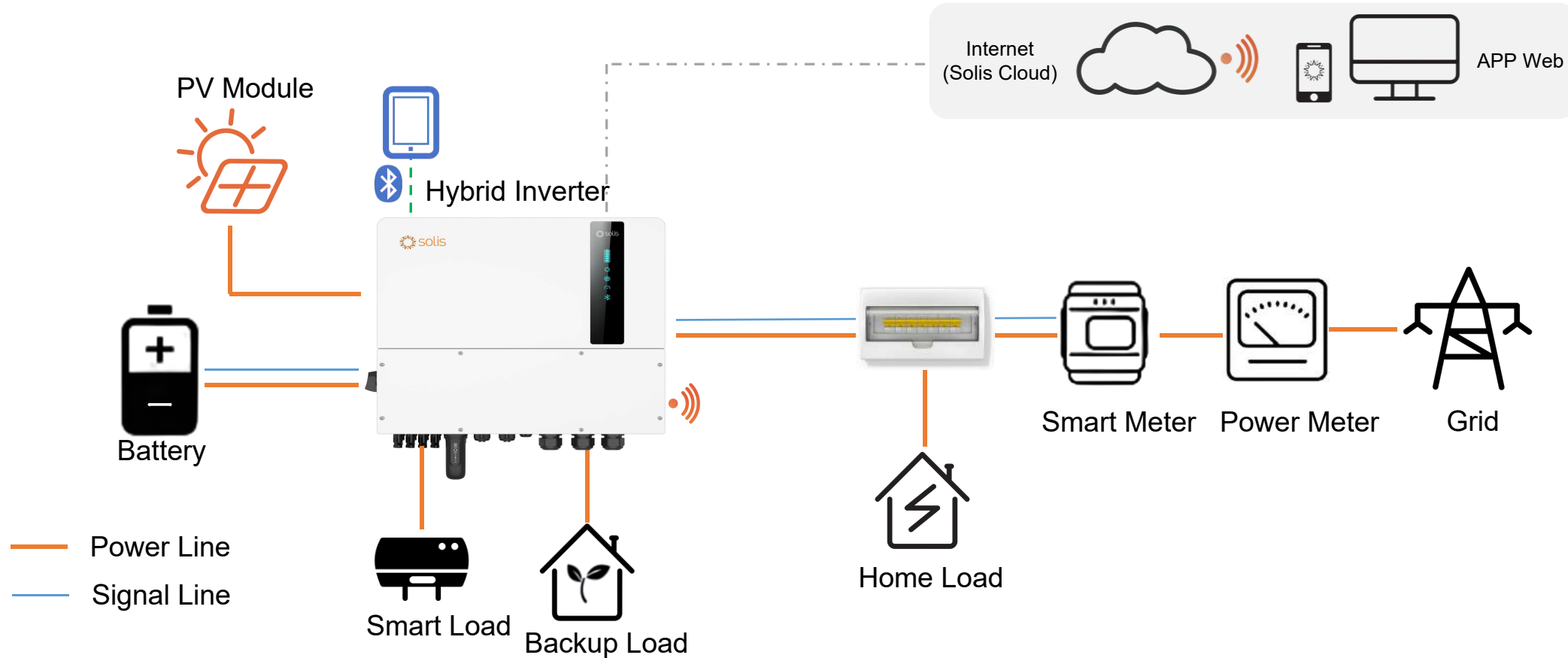

- In this scenario, PV power will supply power to the load and charge the battery, If there is still excess PV power, the inverter will open the power supply to smart load on Gen port, improving self-use proportion.

Residential Single Scenario with 2 Backup (8~15KW)

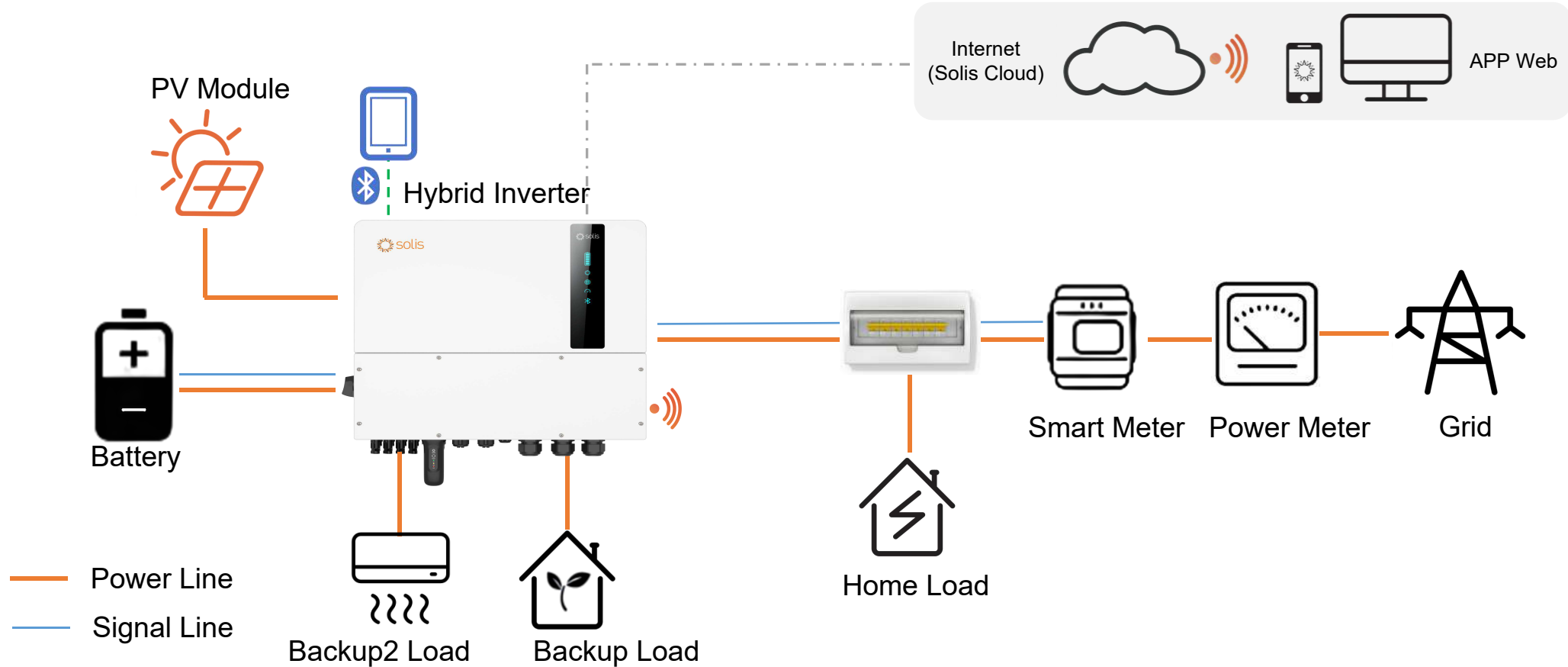

- During power outage , the system can power some non-critical loads used temporarily .
- When the battery energy drops to a certain level, the system will automatically cut off the power supply of these non-critical loads to ensure the power supply of critical loads.

Parallel system on-grid Scenario (8~90KW)

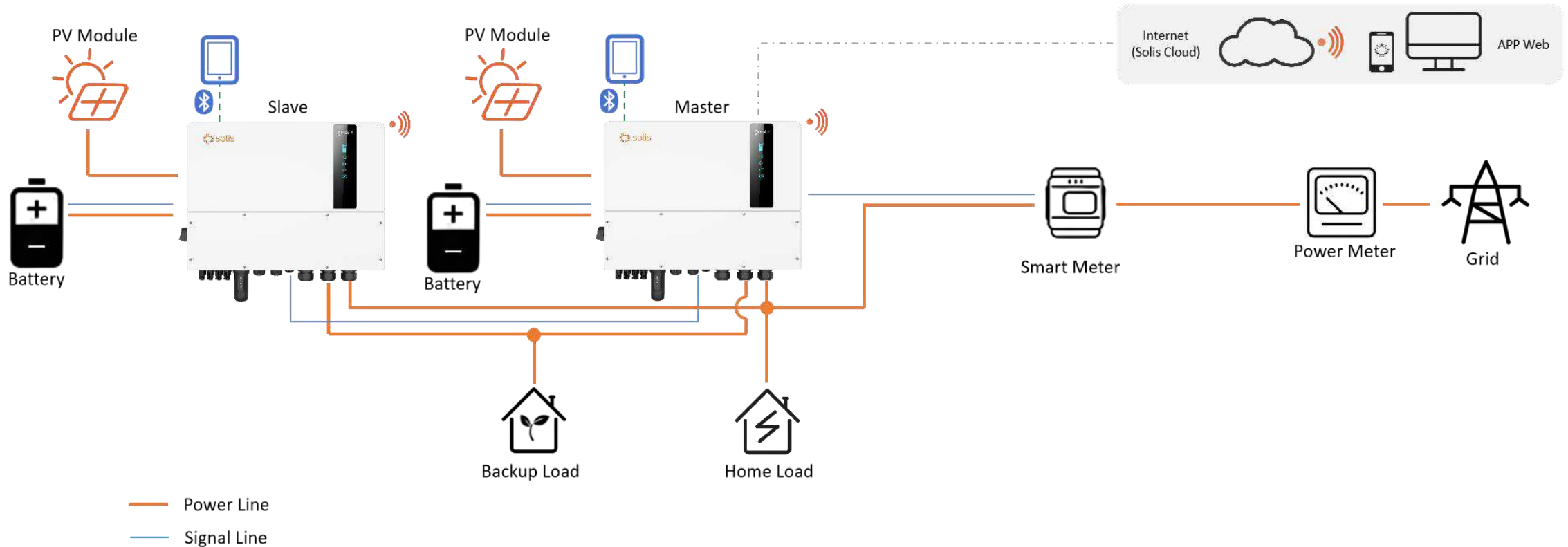

- Maximum 6 in parallel, AC capacity up to 90KW, Battery charge/discharge power up to 90KW.
- The parallel system switch to Emergency Power Supply Mode to power the critical load in 10ms when the grid is power outage.

Off-grid Scenario with Generator (8~15KW)



Generator on AC-gen port

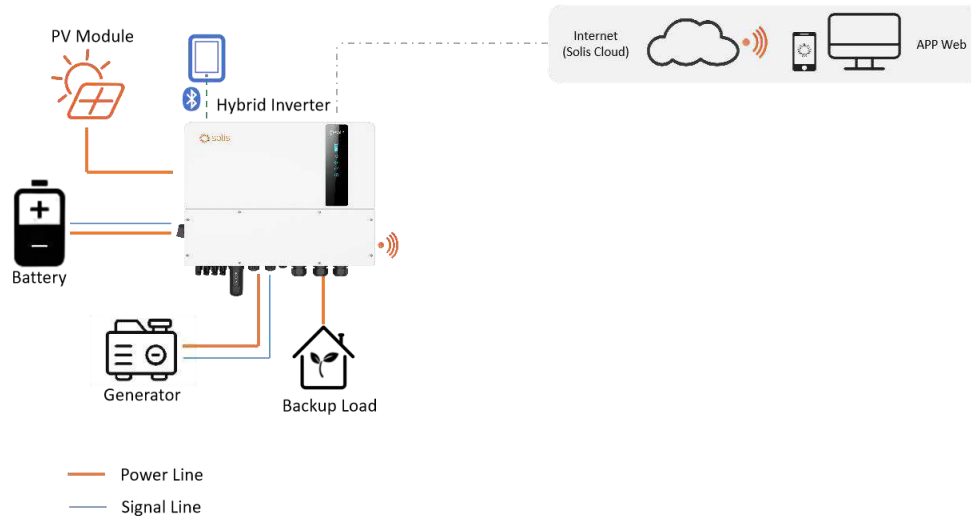

Generator on Grid Side

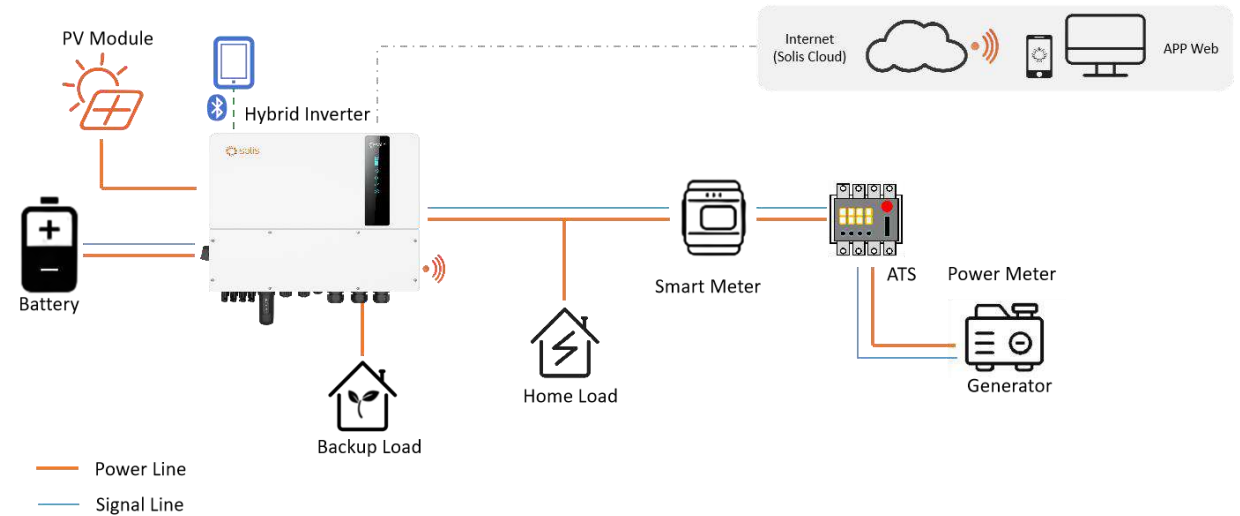

- Support two methods of Generator connection in this scenario, support 24 hours uninterrupted power supply, Intelligent system minimize energy costs.
- Generator on AC-gen port, the system only supply power to Backup Load.
- Generator on Grid side, the system can supply power to both Backup Load and Home Load.

Parallel system off-grid Scenario (8~90KW)

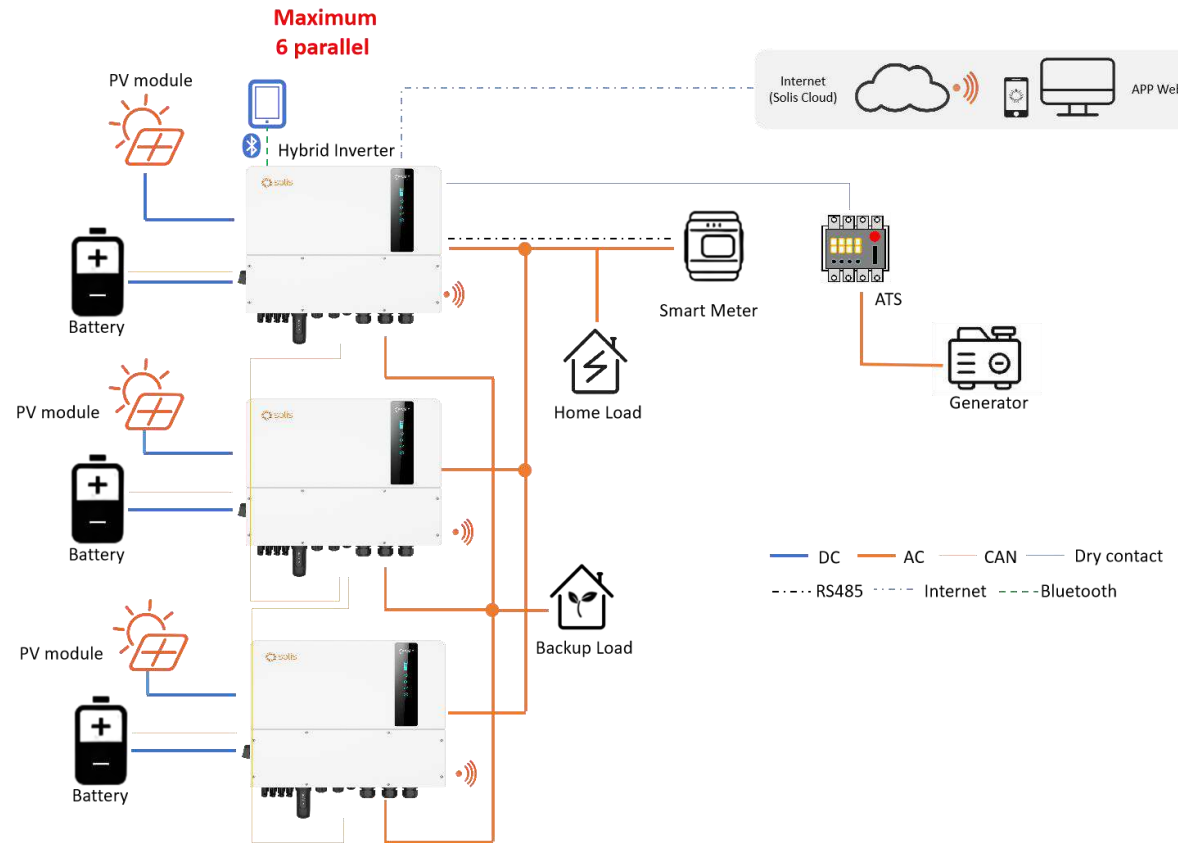

- Maximum 6 in parallel, AC capacity up to 90KW, Battery charge/discharge power up to 90KW.
- Support 24 hours uninterrupted power supply, Intelligent system minimize energy costs.

05

Product basic Installation and setup



Introduction to system setup

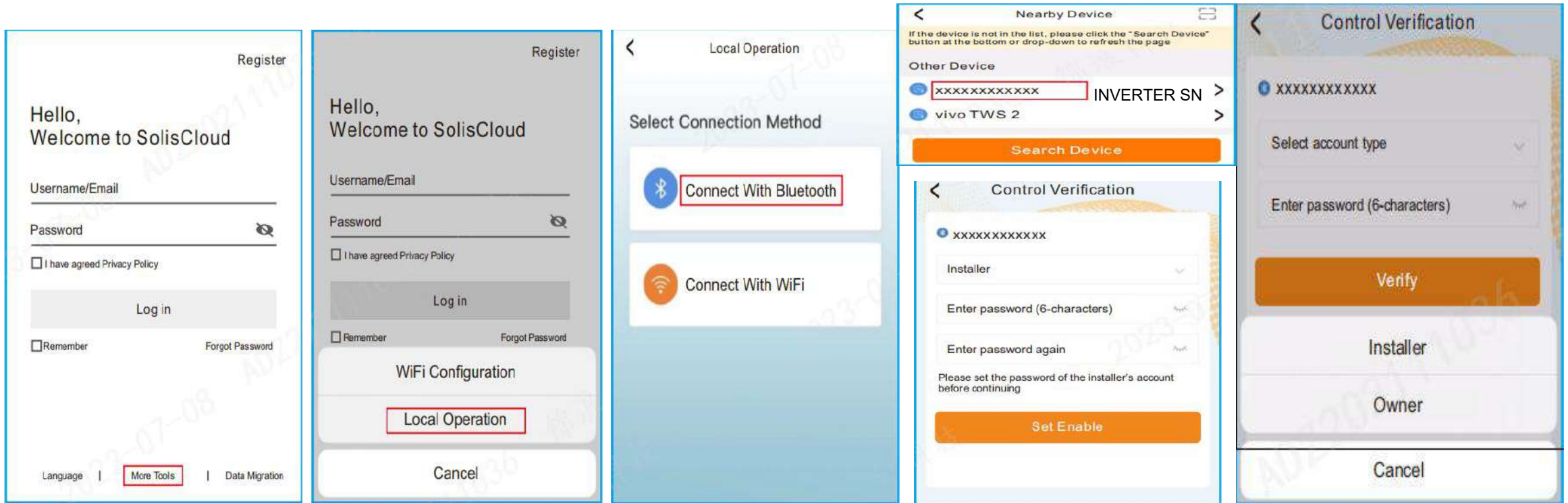

Notice: The installer and Owner's interface are different. In order to prevent change some critical parameters by mis-operations of common users, some settings are not show for Owner's interface. When you log in to the APP for the first time, you need to set the initial Bluetooth password.

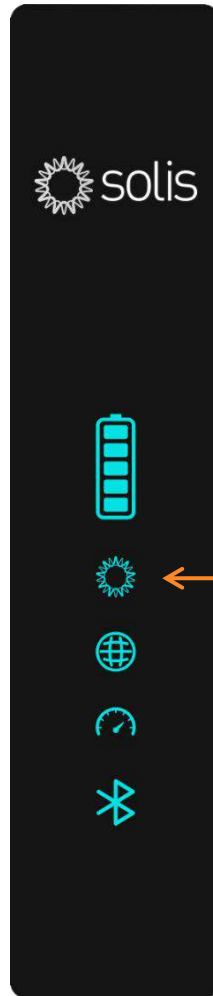

Forget Bluetooth login password how to operate?

Press and hold the power icon for 5s to trigger the function of resetting the built-in Bluetooth password; After the command is triggered, if it success, the running indicator blinks at the blue frequency of 0.5s for 3s and then returns to the normal state, indicating that the reset is successful. If it fails after the command is triggered, the running indicator blinks yellow at a frequency of 0.5s for 3s and then returns to the normal state, indicating that the reset fails

Introduction to system setup

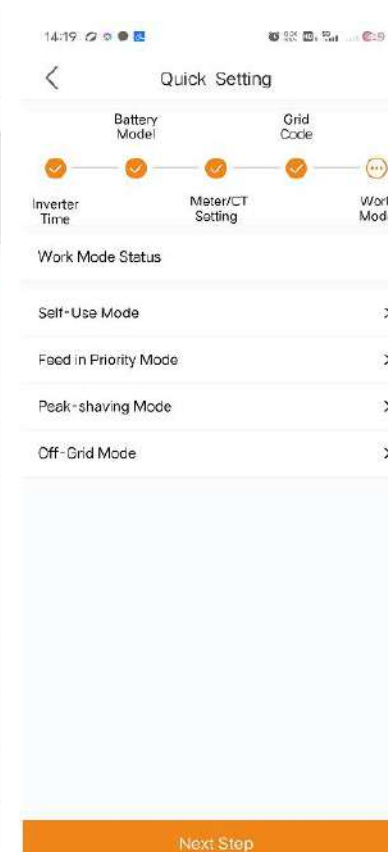
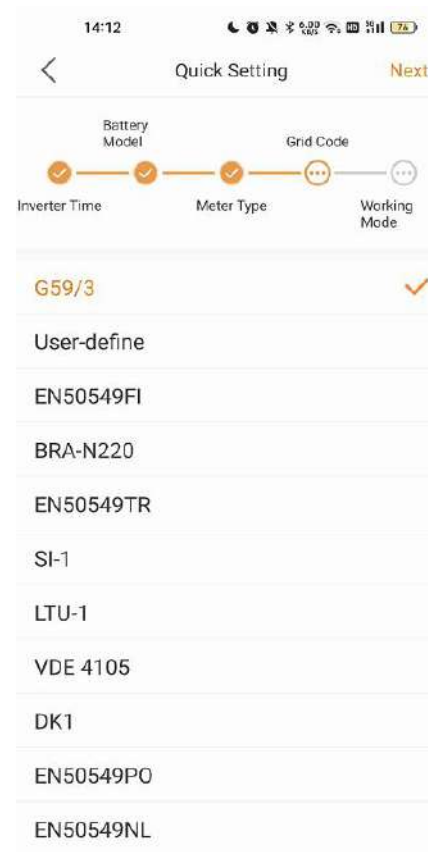
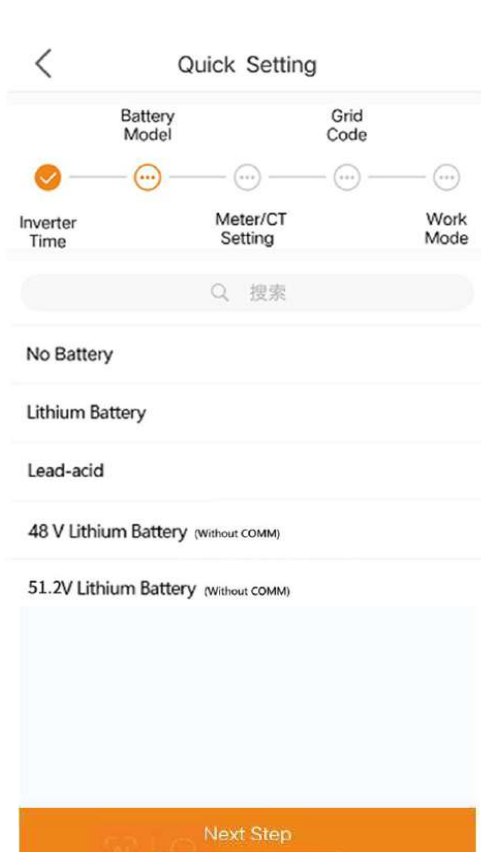

If this is the first time the inverter has been commissioned, you will need to first go through the Quick Settings. After the quick setting, the system can run normally. If you need to set more functions, please enter the APP setting interface to set them

Quick setup guide——Time setup



By default, the system follows phone time. If there is no special requirement, you can directly click the next step

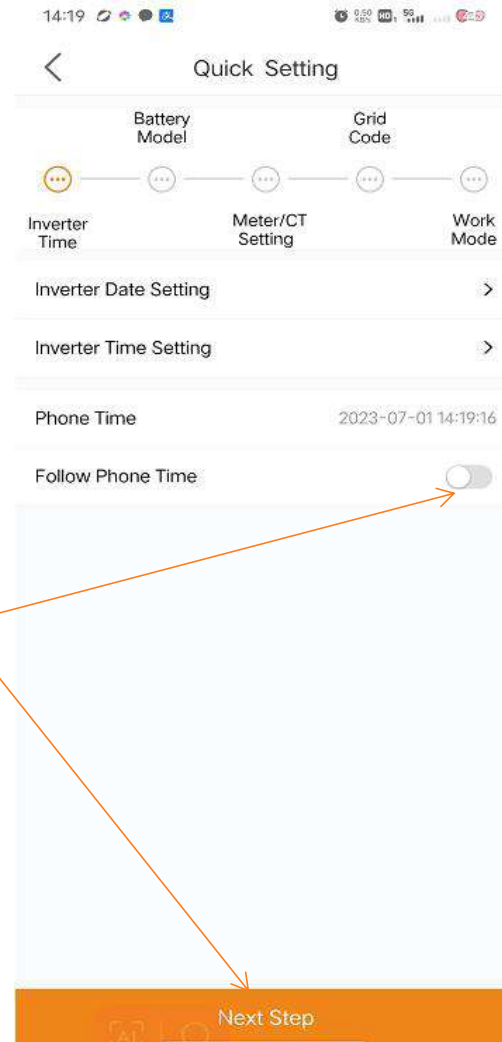

Select Battery type

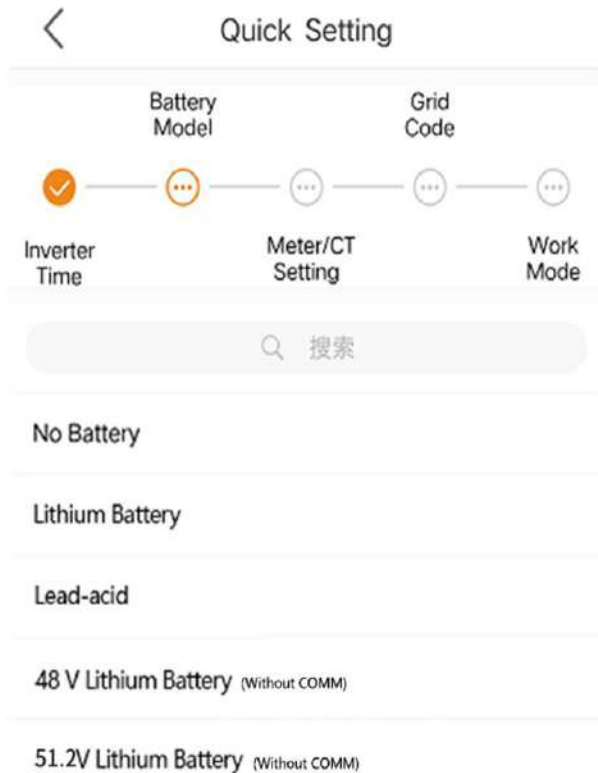

If there is NO Battery connection, select "No battery".
Select 'Lithium Battery' for connected lithium battery
Select 'Lead-acid' for connected lead-acid batteries
If the connection is a non-communication lithium battery, choose according to the battery voltage "48V Lithium Battery(Without CAN Communicatoin) or 52 V Lithium Battery(Without CAN Communicatoin)

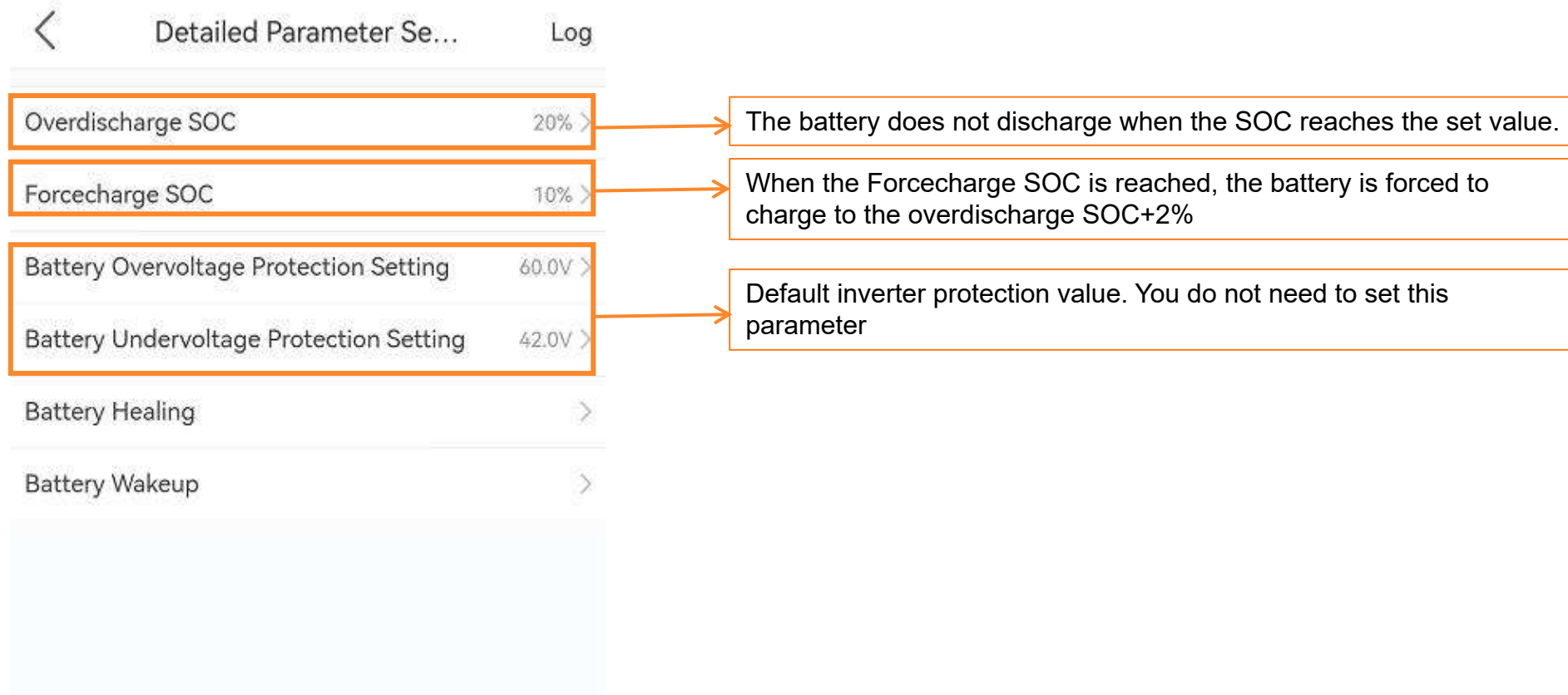

The screenshot shows a mobile application interface for 'Detailed Parameter Settings'. The menu items are: Overdischarge SOC (20%), Forcecharge SOC (10%), Battery Overvoltage Protection Setting (60.0V), Battery Undervoltage Protection Setting (42.0V), Battery Healing, and Battery Wakeup. Three annotations with arrows point to the first three items:

- Overdischarge SOC (20%)**: The battery does not discharge when the SOC reaches the set value.
- Forcecharge SOC (10%)**: When the Forcecharge SOC is reached, the battery is forced to charge to the overdischarge SOC+2%.
- Battery Overvoltage Protection Setting (60.0V)**: Default inverter protection value. You do not need to set this parameter.

Quick setup guide — Battery setup

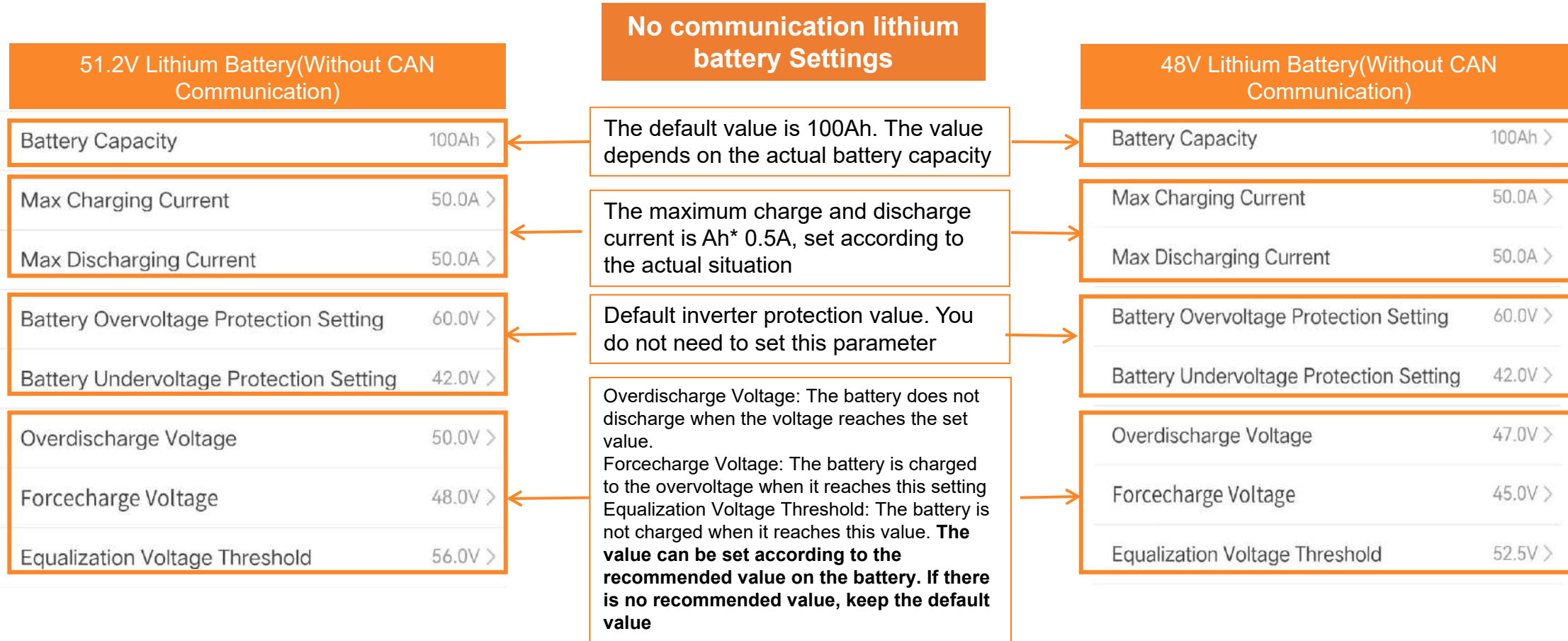

Quick setup guide — Battery setup



Lead-acid battery Settings	
<	Lead-acid Battery Set... Log
Battery Capacity	100Ah >
Max Charging Current	10.0A >
Max Discharging Current	60.0A >
Max Grid Charging Current	0.0A >
Battery Overvoltage Protection Setting	60.0V >
Battery Undervoltage Protection Setting	42.0V >
Overdischarge Voltage	44.5V >
Forcedischarge Voltage	43.8V >
Equalization Voltage Threshold	56.4V >
Temperature compensation coefficient	72mV/°C >
Environment temperature	Normal temperature >

The default value is 100Ah. The value depends on the actual battery capacity

Fill in the recommended value according to the actual use of lead-acid battery specifications, or work according to our default Settings, 50A

•This parameter is not supported

Default inverter protection value. You do not need to set this parameter

Overdischarge Voltage: The battery does not discharge when the voltage reaches the set value.
Forcecharge Voltage: The battery is charged to the overvoltage when it reaches this setting
Equalization Voltage Threshold: The battery is not charged when it reaches this value. **The value can be set according to the recommended value on the battery. If there is no recommended value, keep the default value**

You do not need to set this parameter

You do not need to set this parameter

Quick setup guide——CT setup



CT is connected by default, and the CT ratio is 2000. After confirming that the product is equipped with standard CT, user can directly enter the next step without changing it.

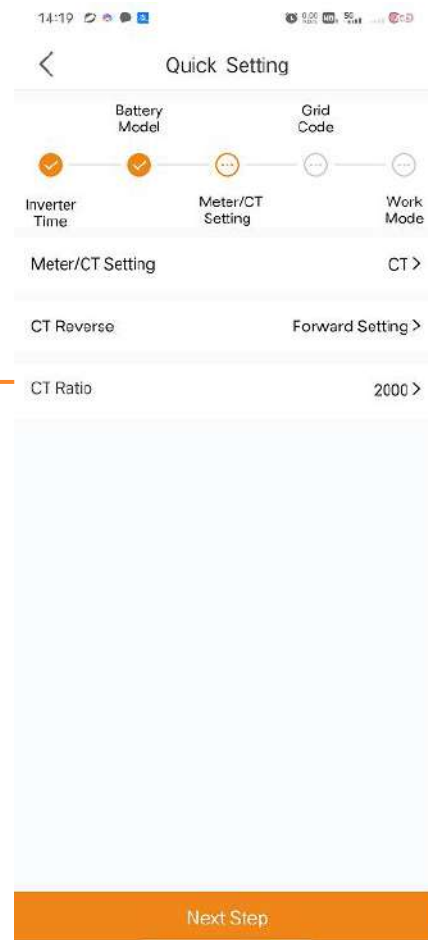

Quick setup guide — Grid standard setup



Set grid standards

Quick Setting

Battery Model Grid Code

Inverter Time Motor/CT Setting Work Mode

Grid Code >

Next Step

Select location

Select Country/Region

General

Other

A

Australia

Austria

B

Barbados

Belgium

Brazil

C

Chile

China

Cyprus, Finland, Czech, Slovenia, Jamaica

D

Denmark

E

Estonia

Select Grid Code

Grid Code Setting Log

Grid Code C10/11 >

OV-G-V 01	264.5V >
OV-G-V-T 01	0.10s >
OV-G-V 02	264.5V >
OV-G-V-T 02	0.10s >
UN-G-V 01	184.0V >
UN-G-V-T 01	0.10s >
UN-G-V 02	184.0V >
UN-G-V-T 02	0.10s >
OV-G-F 01	51.50Hz >
OV-G-F-T 01	0.10s >
OV-G-F 02	51.50Hz >
OV-G-F-T 02	0.10s >
UN-G-F 01	47.50Hz >
UN-G-F-T 01	0.10s >
UN-G-F 02	47.50Hz >

According to the requirements of the local national standard, the inverter has been set before delivery.

The product supports the adjustment of protection parameters. Please use it with the permission of the power grid company.

Quick setup guide—Work Mode



If there is no local TOU price, it is not recommended to use the Time of use function, and the product will automatically control the optimal use of PV energy.

After the Battery Reserve switch is enabled, user can set the value of Reserved SOC to ensure that the battery reserve a certain amount of power to supply the Backup load, when the grid is power outage

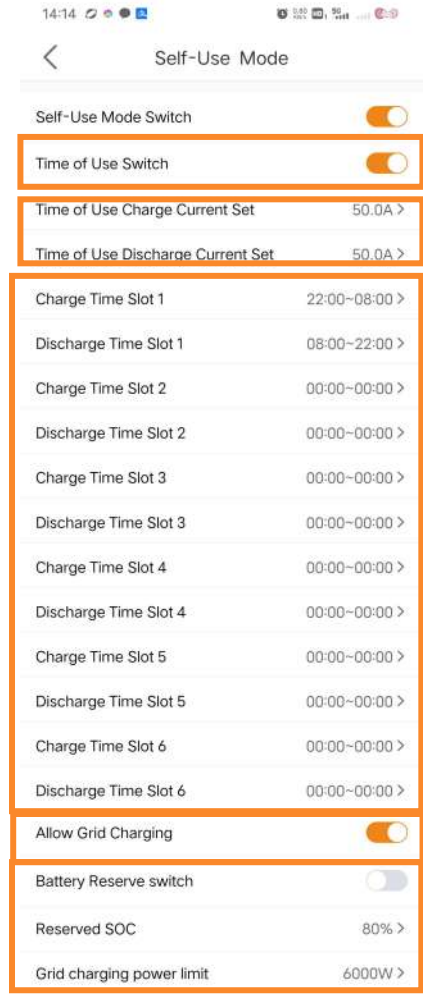

If the electricity price varies in different time periods, user can enable the "time of use" option to manually set the battery charge and discharge time (six periods of charge and discharge time are supported).

Charging and discharging current Settings

6 periods of charging and discharging time Settings

To allow battery charged by the grid

Finish Settings

After basic Settings are complete, the inverter can run normally.

For more information about functions and Settings, see **Product Professional Functions** chapter

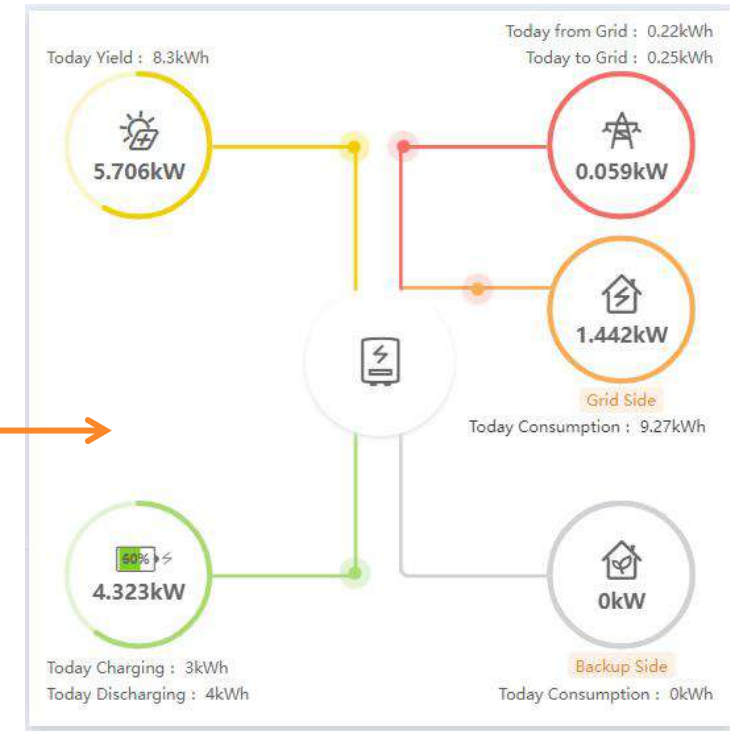

The main interface of SolisCloud platform can directly display the energy yield, purchased power, charging amount, power consumption and other information of inverters. In addition, when inverters are connected in parallel, the parallel system information can also be displayed, so that customers can monitor the running status of inverters in real time.

SolisCloud Platform - Inverter Information Display

Inverter Plant ID: Last Update: 1Min Ago ↻ ★

Operation Record Inverter Control Inverter Upgrade More ▾

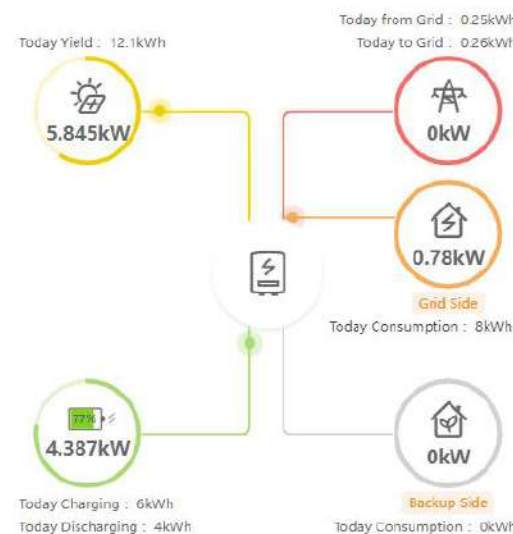

Today Yield : 12.1kWh

Today from Grid : 0.25kWh
Today to Grid : 0.26kWh

5.845kW

0kW

0.78kW
Grid Side

Today Consumption : 8kWh

4.387kW

Today Charging : 6kWh
Today Discharging : 4kWh

0kW
Backup Side

Today Consumption : 0kWh

Real-time Information

Status : ● Online

Current Power : 5.845kW

Today Full Load Hours : 1.21h

Alarm Information : No alarm >

Inverter Internal Operating Ambient Temperature : 51.7°C (up to 105°C)

Basic Information

Name : Inverter	SN :
Rated Power : 10kWp	Plant :
Inverter Version : 050002-120039	Datalogger :
Warranty : 2026-07-07	National Standard : EN50549
Model : 3306	ILeakLim : 240mA
RisoLim : 200kΩ	AFCI Version : 0
Power Up Time : 2023-04-08 19:15:29 (UTC+01:00)Ⓢ	First Power Up Time : 2023-04-09 06:25:29 (UTC+01:00)Ⓢ

Inverter		View >	
Power	5.845kW		
Today Yield	12.1kWh	Total Yield	5.104MWh

Grid		View >	
Power(Discharge)	0kW		
Total Energy Imported	264.49kWh	Total Energy Exported	2.401MWh

Battery		View >	
Power(Charge)	4.387kW	Status	Normal
SOH	100%	SOC	77%

Load		View >	
Total Consumption Power	0.78kW		
Today Consumption	8kWh	Total Consume	2.24MWh

DC	Voltage	Current	Power
PV1	232.6V	11.3A	2628W
PV2	207.9V	4.3A	894W
PV3	266.4V	8.7A	2318W
PV4	0V	0A	0W

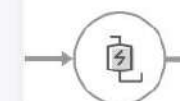

AC	Voltage	Current	F
U	239.2V	2.4A	50.01Hz
V	240.5V	1.1A	50.01Hz
W	238.3V	1A	50.01Hz

激活 Windows

转到“设置”以激活 Windows。

57

Inverter Control

Basic Info

SN : 110CA2229150022 Name : Inverter Model : CA
Related Plant : Schneemeier Status : ● Normal

on off Inverter Time Work Mode Meter Setting

Backup Setting Battery Setting Inverter Parameter Setting Grid Code Setting

System Export Power Setting Special setting Other Setting

SolisCloud platform can realize remote control of the inverter, remote Settings of the inverter parameters, while remote upgrade of the inverter program, intelligent operation and maintenance at your fingertips.

If you want to get the permission of remote control, please contact Solis, sign an agreement before you can get the permission

06

Product Parallel Installation and setup



Wiring Diagram of the Parallel System



Three Phase, 3 PCS in Parallel

Step 1 Connect cables to the parallel system

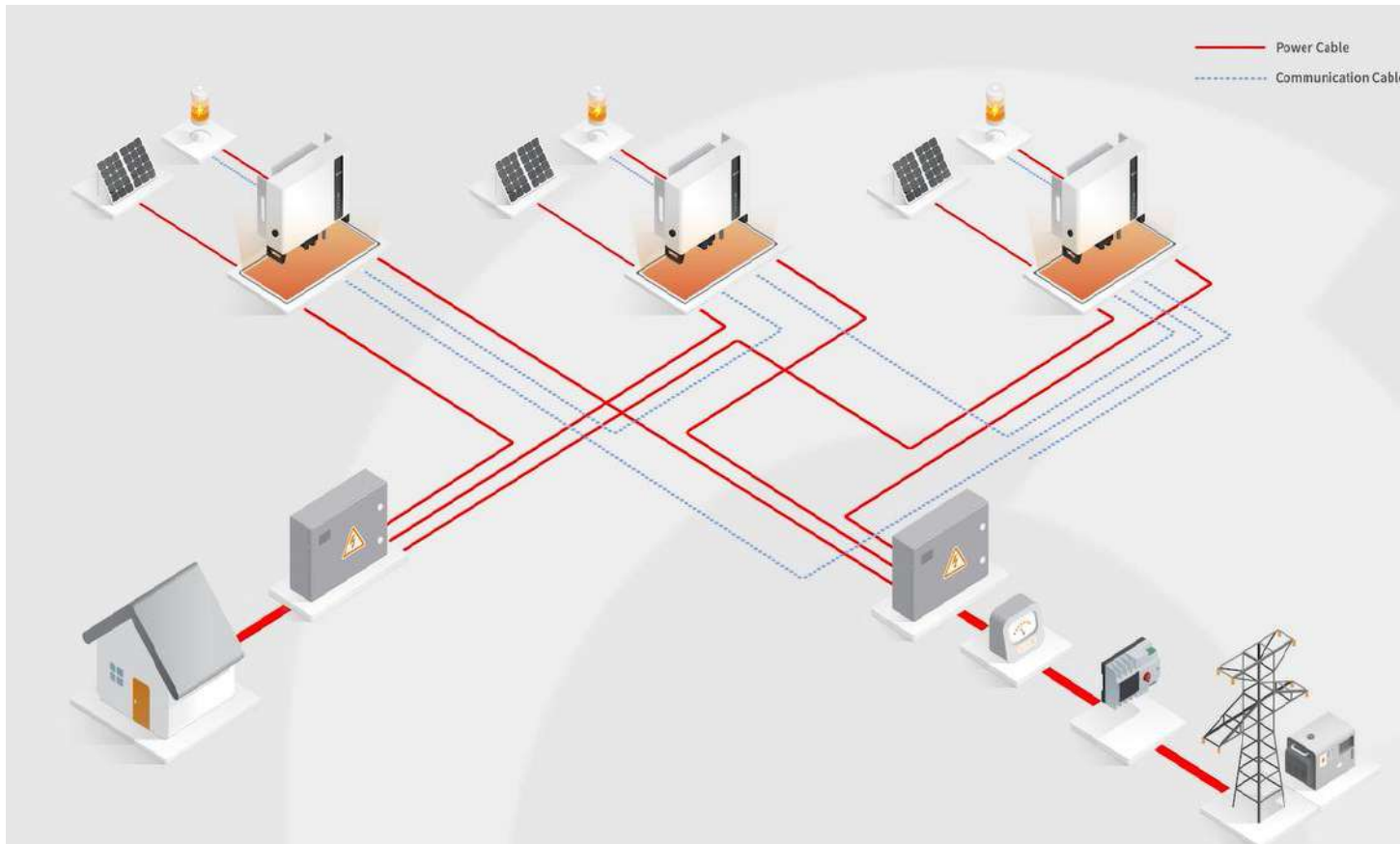

Step 2 Adjust the inverter dip switch

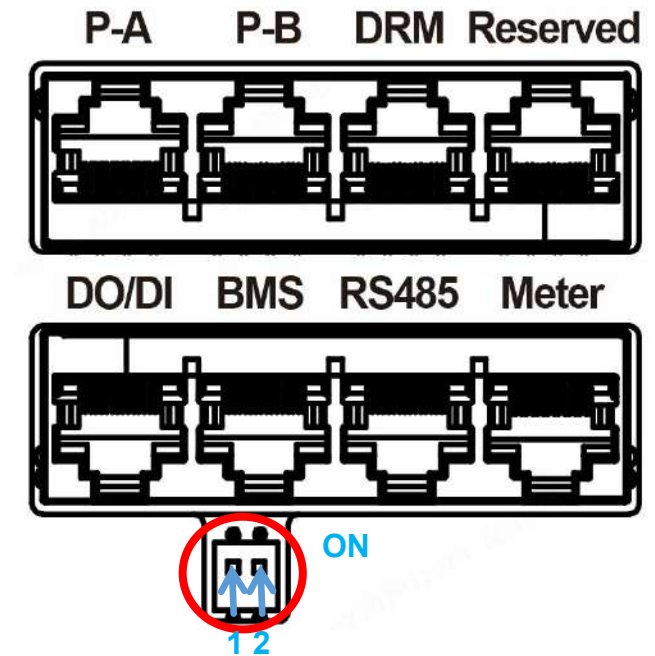

DIP Switch: Both the first and the last inverter(INV1 & INV3) have 2 DIP switches enabled (Both Pin1 & Pin2)

Parallel System Setting

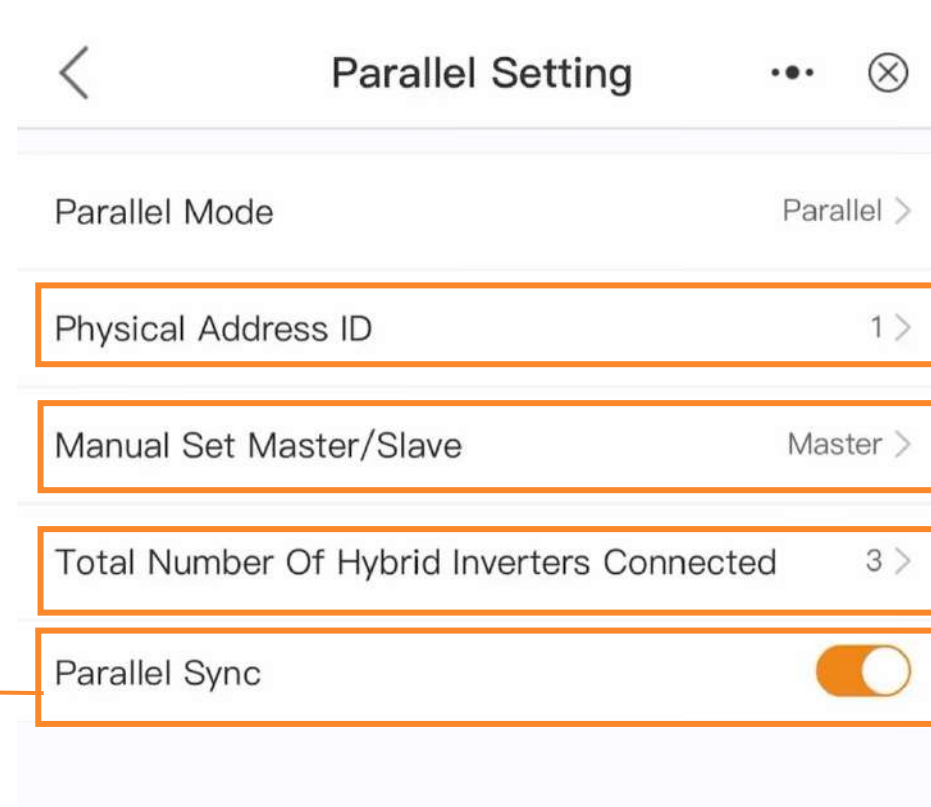

The first inverter address is set to 1, the second to 2, and so on (**Note:** that the address cannot be set to 0)

The physical address of the master must be 1

Number of inverters in parallel, range (2~6)

With synchronous setting, that is, any parallel parameters of the main inverter can be synchronized to the slave inverter, saving work and reducing operation errors

Parallel System Demonstration

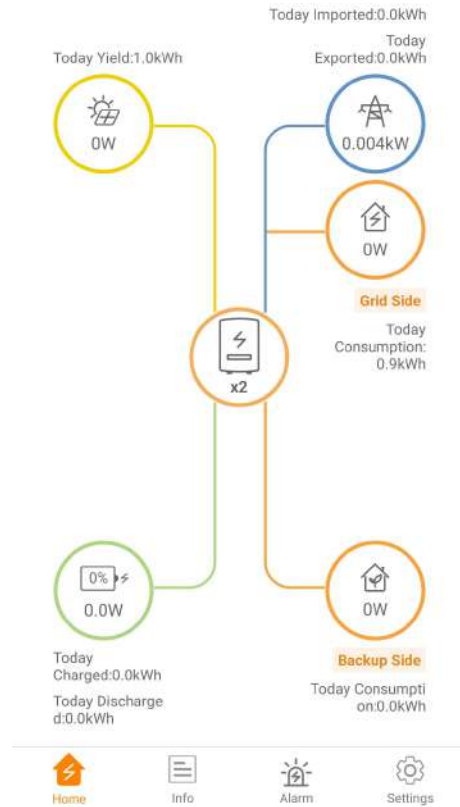

After the parallel setting, connect the main inverter bluetooth and view the parallel system through the app.

Parallel fault handling



Fault name	Code	suggest
The synchronization signal of the master computer is lost abnormally	MasterLoseErr(1061)	<ol style="list-style-type: none"> 1, check whether the parallel line is loose, resulting in no communication; 2, whether the parallel line in the product accessories is not used; 3. Check whether it is an 8-core wire, the communication is disconnected due to the lack of core; 4, check whether the wire has a shielding layer; 5. Restart the inverter. If the fault persists, contact customer service.
The synchronization signal period of the slave is abnormal	SlavePrd-Err(1062)	<ol style="list-style-type: none"> 1, check the quality of the local grid, poor grid quality may lead to the problem; 2. Check whether the parallel signal circuit is abnormal; 3. Restart the inverter. If the fault persists, contact customer service.
The synchronization signal period of the master computer is abnormal	MasterPrd-Err(1063)	<ol style="list-style-type: none"> 1, check the quality of the local power grid, poor power grid quality may lead to the problem; 2. Check whether the parallel signal circuit is abnormal; 3. Check whether the parallel signal lines are connected correctly; 4. Restart the inverter. If the fault persists, contact customer service.
Physical address conflict	Addr-Conflict(1064)	<ol style="list-style-type: none"> 1. Check whether two or more machines in the parallel system have the same address 2. If the fault still cannot be cleared, restart the inverter. If the fault persists, contact customer service.
Heartbeat packet loss	HeartbeatLose(1065)	<ol style="list-style-type: none"> 1. Check whether the host address in the parallel system is set to 0, and the address must start from 1; 2. Check whether the parallel signal circuit is abnormal; 3. Check whether the parallel signal lines are connected correctly; 4. Restart the inverter. If the fault persists, contact customer service.
The DCAN register is abnormal	DCanErr(1066)	<ol style="list-style-type: none"> 1, check whether the parallel line is loose, loose may lead to no communication; 2, whether the parallel line in the product accessories is not used; 3. Check whether the 8-core wire is not used, and the communication is disconnected due to the lack of core; 4, check whether the wire without shielding layer; 5, check the hardware problems (can communication device damage, power supply or serious interference, etc.); 6. Restart the inverter. If the fault persists, contact customer service.

Parallel fault handling



Fault name	Code	suggest
Multiple master errors	MulMasterErr(1067)	<ol style="list-style-type: none"> 1. Check whether there are 2 or more masters in the parallel system; 2. Check whether the host address in the parallel system is set to 0, and the address must start from 1; 3. If the fault still cannot be cleared, restart the inverter. If the fault persists, contact customer service.
The master & saver on-grid and off-grid modes are not synchronized	ModeConflict(1068)	<ol style="list-style-type: none"> 1, check whether the parallel line is loose, resulting in no communication; 2, whether the parallel line in the product accessories is not used; 3. Check whether it is an 8-core wire, the communication is disconnected due to the lack of core; 4, check whether the wire has a shielding layer; 5. Restart the inverter. If the fault persists, contact customer service.
When the master is offline, the voltage is not synchronized with the master when the saver is connected	S-PlugVoltErr(1069)	<ol style="list-style-type: none"> 1. Check whether the phase sequence of the AC side of the slave is consistent with that of the master; 2. Restart the inverter. If the fault persists, contact customer service.
Other inverters are faulty	Others'Fault(106A)	<ol style="list-style-type: none"> 1, check the failure of the master, so as to troubleshoot; 2. Restart the inverter. If the fault persists, contact customer service.
The slave synchronization signal is lost abnormally	SlaveLoseErr(1060)	<ol style="list-style-type: none"> 1, check whether the parallel line is loose, resulting in no communication; 2, whether the parallel line in the product accessories is not used; 3. Check whether it is an 8-core wire, the communication is disconnected due to the lack of core; 4, check whether the wire has a shielding layer; 5. Restart the inverter. If the fault persists, contact customer service.
The CAN bus is lost	CAN BUS LOSE (106B)	<ol style="list-style-type: none"> 1, check whether the parallel line is loose, loose may lead to no communication; 2, whether the parallel line in the product accessories is not used; 3. Check whether the 8-core wire is not used, and the communication is disconnected due to the lack of core; 4, check whether the wire without shielding layer; 5, check the hardware problems (can communication device damage, power supply or serious interference, etc.); 6. Restart the inverter. If the fault persists, contact customer service.
Three-phase networking exception	NO	<ol style="list-style-type: none"> 1. Check the setting of the connected phase sequence in the three-phase networking system. If no inverter is set on a phase or multiple phases, a fault is reported. 2. If the fault still cannot be cleared, restart the inverter. If the fault persists, contact customer service.

07

Product Professional Functions



How to setup for generator?

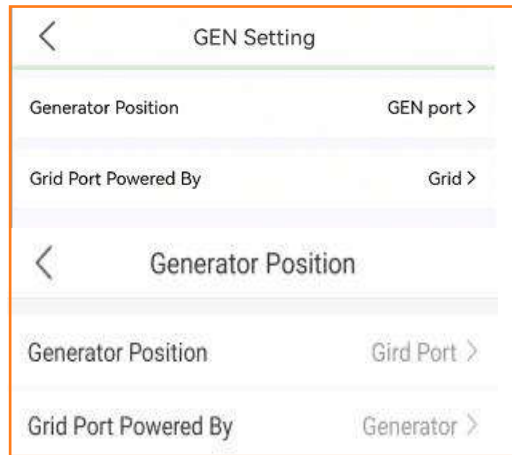

3. Set the position of the generator, Perform a variety of generators connection mode

NOTE: You can choose GEN port or Grid port. When you choose to connect the generator to the grid port, you must correctly select the power source of the grid port, otherwise the generator will be damaged



1. Turn on the with generation switch

2. Set the generator rating

4. Automatically start and stop the generator according to the set SOC/voltage when there is no power grid

5. select GEN Signal



GEN signal

Yes means that the generator has automatic start-stop function, which can be controlled by the inverter.
No means that the generator has no automatic start-stop function and needs manual control.

If the generator start-stop condition is not met, forcibly start and stop the generator

How to setup for AC Coupling?

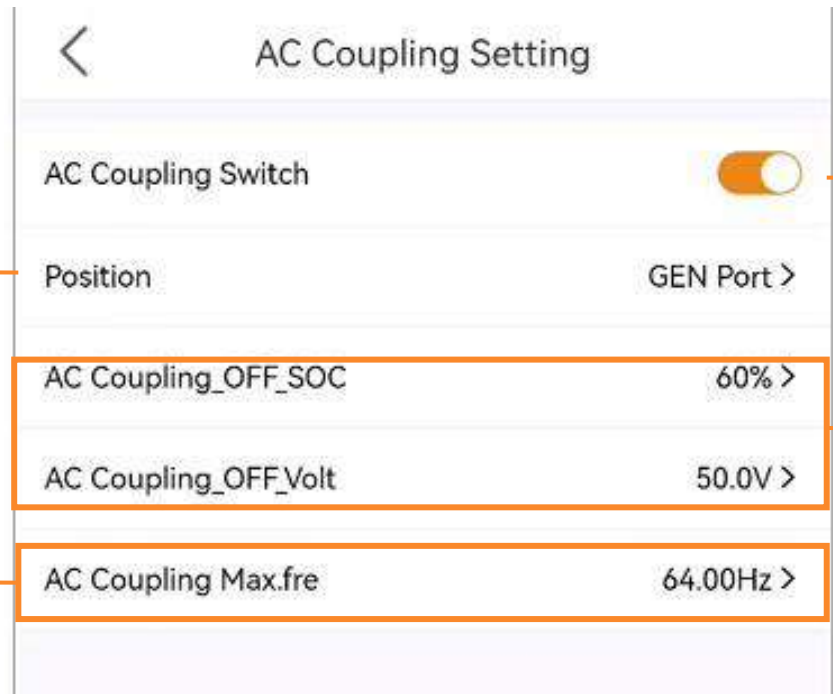

The screenshot shows the 'AC Coupling Setting' menu with the following items:

- AC Coupling Switch:
- Position: GEN Port >
- AC Coupling_OFF_SOC: 60% >
- AC Coupling_OFF_Volt: 50.0V >
- AC Coupling Max.fre: 64.00Hz >

Annotations and instructions:

- 1. Turn on the AC Coupling switch (points to the AC Coupling Switch)
- 2. Set the position of the PV inverter, generator port/backup port (points to the Position)
- 3. Set the lithium battery OFF SOC or lead-acid battery OFF voltage. (points to the AC Coupling_OFF_SOC and AC Coupling_OFF_Volt)
- 4. The default value is the local level overfrequency $\pm 0.1\text{Hz}$, which does not need to be changed (points to the AC Coupling Max.fre)

Example:
OFF SOC = 90%.
Max Fre = 52Hz.

When hybrid inverter's battery SOC is increasing to 80% (OFF SOC-10%). Hybrid inverter starts to increase the frequency of the backup port. And PV inverter will reduce its output power with increasing frequency. Until battery SOC reaches 90%(OFF SOC), the backup frequency will reach 52Hz(Max Fre)

SOC = 80%(OFF-SOC-10%) -> 50Hz
SOC = 85% -> 51Hz
SOC = 90% (OFF-SOC) -> 52Hz

How to set Peak-shaving mode?

3. on the premise that the power supplied by the grid is below the set value of **Max usable Grid Power**
It will be used to charge the battery and support the load.

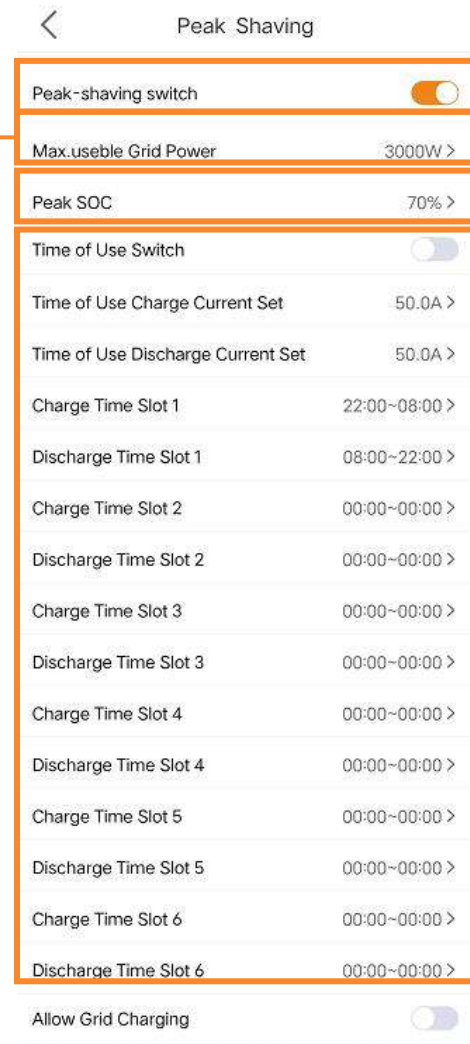

The screenshot shows the 'Peak Shaving' configuration screen. At the top, there is a back arrow and the title 'Peak Shaving'. The settings are as follows:

- Peak-shaving switch:
- Max.usable Grid Power: 3000W >
- Peak SOC: 70% >
- Time of Use Switch:
- Time of Use Charge Current Set: 50.0A >
- Time of Use Discharge Current Set: 50.0A >
- Charge Time Slot 1: 22:00~08:00 >
- Discharge Time Slot 1: 08:00~22:00 >
- Charge Time Slot 2: 00:00~00:00 >
- Discharge Time Slot 2: 00:00~00:00 >
- Charge Time Slot 3: 00:00~00:00 >
- Discharge Time Slot 3: 00:00~00:00 >
- Charge Time Slot 4: 00:00~00:00 >
- Discharge Time Slot 4: 00:00~00:00 >
- Charge Time Slot 5: 00:00~00:00 >
- Discharge Time Slot 5: 00:00~00:00 >
- Charge Time Slot 6: 00:00~00:00 >
- Discharge Time Slot 6: 00:00~00:00 >
- Allow Grid Charging:

1. Turn on the Peak-shaving switch

4. Setting the Peak SOC on the premise that the power supplied by the grid is below the set value, the system will try to charge the battery to Peak SOC as far as possible.

TOU in Peak-shaving mode
If the electricity price varies in different time periods, user can enable the "time of use" option to manually set the battery charge and discharge time (six periods of charge and discharge time are supported).

- 6. Multiple battery protection function.

1.ECO function: To protect the battery, If PV power is lower than 100W and SOC falls below overdischarge SOC, The inverter will not use battery power

2.Battery Healing Function: When the lithium battery is kept low for a long time, the measurement of the battery SOC is not accurate. This function will charge the battery to the set battery Healing SOC when the battery reaches the discharged SOC, so as to ensure the healthy and stable operation of the battery

3.Battery Wake up function: When the battery power is too low, the inverter can wake up the battery. The inverter can wake up the battery in two wake up modes: manual wake up and automatic wake up. You can set the wake up voltage and wake up voltage duration in both modes

4.Battery Peak shaving function: In some areas, customers hope to avoid Max charging power and Max load running at the same time, otherwise it will cause the home circuit breaker to trip, by setting the force charge power value, the force charge power is dynamically adjusted according to the set value.

How to use Multiple battery protection function?

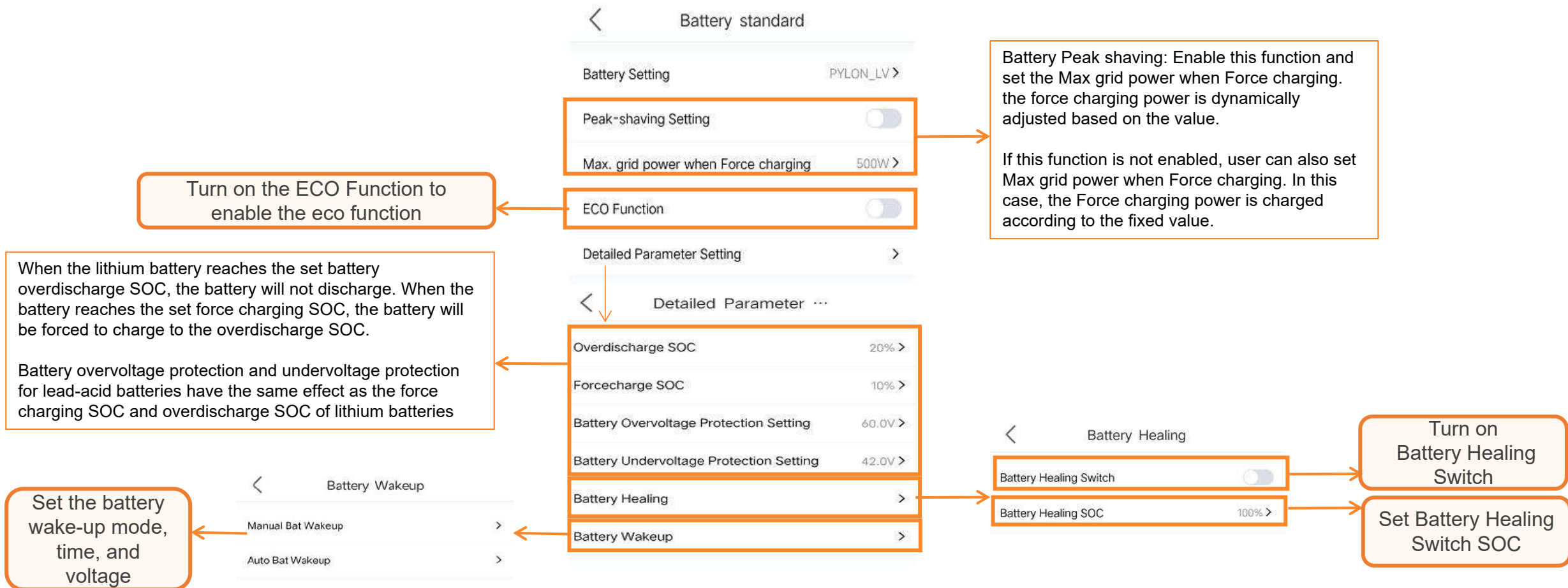

Keypard



There are four keys in the front panel of the inverter (from left to right):
ESC, UP, DOWN and ENTER keys. The keypad is used for:

- Scrolling through the displayed options (the UP and DOWN keys);
- Access and modify the settings (the ESC and ENTER keys).

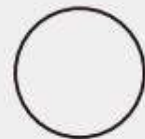

ESC



UP

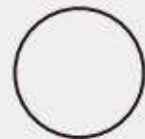

DOWN

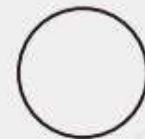

ENTER

LED indicators



There are three LED indicators on the RHI inverter (Red, Green, and Orange) which indicate the working status of the inverter.



Light	Status	Description
● POWER	ON	The inverter can detect DC power.
	OFF	No DC power.
● OPERATION	ON	The inverter is fully operational.
	OFF	The inverter has stopped operating.
	FLASHING	The inverter is initializing.
● ALARM	ON	Fault condition is detected.
	OFF	No fault condition detected.
	FLASHING	Either the grid or solar cannot be detected.

Enter Settings



Menu 2024-01-16 16:50

Information

Settings

Alarm Information

Advanced Settings

ESC UP **DOWN** ENTER

Settings 2024-01-16 16:50

Inverter Power ON/OFF

Smart Port

Time Setting

Parallel Setting

Meter Setting

Grid Feed in Power Setting

Work Mode

Special Function Setting

Battery Setting

Language Settings

Grid Setting

ESC UP DOWN **ENTER**

Inverter power on/OFF



Settings 2024-01-16 16:50

Inverter Power ON/OFF	Smart Port
Time Setting	Parallel Setting
Meter Setting	Grid Feed in Power Setting
Work Mode	Special Function Setting
Battery Setting	Language Settings
Grid Setting	

ESC UP DOWN ENTER

Inverter Power ON/OFF 2024-01-16 16:50

Inverter Power ON
Inverter Power OFF

ESC UP DOWN ENTER

Time Settings



Settings 2024-01-16 16:50

Inverter Power ON/OFF	Smart Port
Time Setting	Parallel Setting
Meter Setting	Grid Feed in Power Setting
Work Mode	Special Function Setting
Battery Setting	Language Settings
Grid Setting	

ESC UP **DOWN** ENTER

Time Setting 2024-01-16 16:50

YY MM DD HH MM

2024 - 01 - 16 17 : 25

ESC UP **DOWN** ENTER

Grid Settings



Settings 2024-01-16 16:50

Inverter Power ON/OFF	Smart Port
Time Setting	Parallel Setting
Meter Setting	Grid Feed in Power Setting
Work Mode	Special Function Setting
Battery Setting	Language Settings
Grid Setting	

ESC UP DOWN ENTER

Grid Setting 2024-01-16 16:50

Select Standard

G59/3

ESC UP DOWN ENTER

Parallel Settings



Settings 2024-01-16 16:50

Inverter Power ON/OFF	Smart Port
Time Setting	Parallel Setting
Meter Setting	Grid Feed in Power Setting
Work Mode	Special Function Setting
Battery Setting	Language Settings
Grid Setting	

ESC UP DOWN ENTER

Parallel Setting 2024-01-16 16:50

Parallel Mode	
Physical Address ID	
Manual Set Master/Slave	Master
Inverter Connected Phase Setting	

ESC UP DOWN ENTER

Feed-in limitation Settings



Settings 2024-01-16 16:50

Inverter Power ON/OFF	Smart Port
Time Setting	Parallel Setting
Meter Setting	Grid Feed in Power Setting
Work Mode	Special Function Setting
Battery Setting	Language Settings
Grid Setting	

ESC UP DOWN ENTER

Grid Feed in Power Setting 2024-01-16 16:50

Feed in Power Limit Swtich	
Feed in Power Limit Value	500W
Meter Compensation	
Feed in Current Limit Swtich	
Feed in Current Limit Value	
Internal EPM Hard Limit Switch	
Power Hard Limit Value	
Failsafe Switch	

ESC UP DOWN ENTER

Advanced Settings



Menu 2024-01-16 16:50

Information

Settings

Alarm Information

Advanced Settings

ESC UP DOWN ENTER

Advanced Settings 2024-01-16 16:50

Grid Code Advanced Setting	Phase A Voltage Compensation
Clear Yield Data	Special Function Setting 1
Factory Reset	Special Function Setting 2
Restart HMI	Special Function Setting 3
Inverter Output Power Setting	AFCI Setting
Power Factor Setting	No Boost
Calibration Setting	DC Inject Adj
POE Setting	

ESC UP DOWN ENTER

06

Reliability





“Since its launch in 2005, Solis has been driven by innovation and development. Continuously improving its ability to respond to global market demands now offering fifth generation technology.”

-Mr. Zhang- Chief Product Manager at Solis Global HQ



R&D expenditure has increased year by year

2022

74%



Surface Mounted Technology Workshop



Wave Soldering Machine



Printed Circuit Board Coating Room



Dual In-line Package Machine

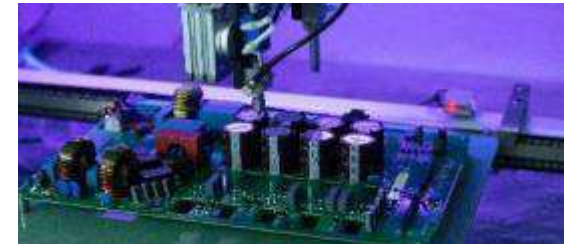

Spraying Machine



Surface Mounted Technology Machine



Solder Paste Inspection



Assembly Line



Auto aging test

Top-of-range Lifespan Projection in String Inverter Category as Validated by DNV-GL



The inverter life models presented are positively impacted by the long and impressive track record of PV inverters designed and manufactured by Ginlong. The useful life projections are at or near the top of the string inverter life projections.

— DNV-GL



The company to receive awards for **8** consecutive years

— EUPD



Reliability of Components



- 100% of inverters produced are tested before shipment
- We only use genuine MC4 connectors (Staubli)



The inverter life models presented were positively impacted by the long and impressive track record of PV inverters designed and manufactured by Ginlong. The useful life projections are at or near the top of the string inverter life projections by DNV·GL.

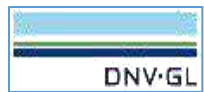

Source DNV·GL

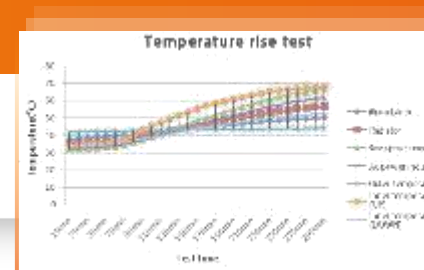



27 Service Centers

With 27 offices and service centers around the world, including the Australia, Brazil, China, Chile, France, Germany, India, Italy, Indonesia, Korea, Mexico, Myanmar, Malaysia, Netherlands, Philippines, Poland, Pakistan, Romania, South Africa, Spain, Sweden, Singapore, Turkey, Thailand, UK, USA and Vietnam, Solis has a well-established and expanding global presence.

HQ

Service Centers

Response time

2H

Replacement time

24H

On-site support time

48H

Ginlong Technologies Co.,Ltd

• **Website: solisinverters.com** •

Address: NO.188 Jinkai Road, Xiangshan,Ningbo, Zhejiang,China